

**UNITED STATES  
DEPARTMENT OF THE INTERIOR  
BUREAU OF LAND MANAGEMENT  
Northwest Oregon District Office  
1717 Fabry Road, S.E.  
Salem, Oregon 97306**

**Humbard's Timber Sale  
ORN02-TS-2024.0203  
Date: July 29, 2024**

**TIMBER SALE PROSPECTUS**

**THIS IS A PROSPECTUS ONLY. ATTACHMENTS MAY NOT INCLUDE ALL EXHIBITS REFERRED TO IN THE CONTRACT. THE COMPLETE CONTRACT, INCLUDING ALL EXHIBITS, IS AVAILABLE FOR INSPECTION AT THE NORTHWEST OREGON DISTRICT OFFICE.**

NOTICE IS HEREBY GIVEN that the Bureau of Land Management will offer for sale timber as described herein for oral auction, pursuant to Instructions to Bidders, as stated on Form No. 5440-9. Written and oral bids will be received by the District Manager, or designated representative, in the timber sale room at the District Office, 1717 Fabry Road, S.E., Salem, Oregon. Written bids and deposits will be accepted beginning at 8:30 a.m. and the timber sale oral auction will commence at 9:00 a.m., on Wednesday, August 28, 2024. Before bids are submitted, full information concerning the timber, the conditions of sale and submission of bids, including appraised prices per species, should be obtained from the above District Manager, or designated representative. The right is hereby reserved to waive technical defects in this advertisement and to reject any or all bids. The United States reserves the right to waive any informality in bids received whenever such waiver is in the interest of the United States.

THIS PROSPECTUS does not constitute the decision document for purposes of appeal of a forest management decision. Consistent with 43 CFR Subpart 5003.2(b), the date the BLM posts the forest management decision on the BLM's ePlanning website establishes the effective date of the decision for purposes of an administrative appeal. The decision was posted to the BLM's ePlanning website on 06/18/2024, referring to the Little K Forest Management Project, DOI-BLM-ORWA-N020-2019-0011-EA. For the purposes of 43 CFR 5401.0-6 and 5430.0-6, this advertisement is being published on July 29, 2024 and August 5, 2024 on the BLM Timber Sale Notice Website.

AN ENVIRONMENTAL ASSESSMENT was prepared for this timber sale tract, and a Finding of No Significant Impact has been documented. These documents are available for inspection as background for each timber sale tract at the Northwest Oregon District Office.

A WRITTEN BID on Form 5440-9 at not less than the advertised appraised price on a unit basis per species and the required minimum bid deposit shall be required to participate in oral bidding.

THE SUCCESSFUL BIDDER, as a condition of award, will be required to sign Form 5430-11, a certification that the bid was arrived at by the bidder or offeror independently, and was tendered without collusion with any other bidder or offeror. Also, Form 5450-17, Export Determination must be completed by the successful bidder. To expedite procedure, this form should be completed and submitted with the written bid.

THE VOLUMES LISTED herein are estimates only. The sale volumes listed are based on 16-foot taper breaks which must be taken into consideration if comparisons are made with volume predictions based on other standards. The volumes based on 32-foot taper breaks are shown for comparison purposes. No sale shall be made for less than the advertised appraised price. The Purchaser shall be liable for the total purchase price, without regard to the amount bid per unit, even though the quantity of timber actually cut or removed or designated for taking is more or less than the estimated volume or quantity so listed.

THIS TIMBER SALE has been cruised based upon Eastside Scribner board foot measure. The minimum bid figures shown by species are dollars per thousand board feet (MBF). The minimum bid increment will be \$0.10 per MBF.

A PERFORMANCE BOND in an amount not less than 20 percent of the total purchase price will be required for all contracts of \$2,500 or more. A minimum performance bond of not less than \$500 will be required for all installment contracts less than \$2,500.

QUALIFIED SMALL BUSINESS concerns may apply to SBA for a loan to provide financing for access road construction required under the terms of qualifying timber sale contracts, and necessary contract changes will be made. Approval of loan applications rests with SBA and may be contingent on availability of funds. Applicants for such loans shall notify BLM of their intention to apply for a loan.

PRE-AWARD QUALIFICATIONS. The high bidder may be required to furnish information to determine the ability to perform the obligations of the contract. If the high bidder is determined not qualified, responsible or refuses to respond within fifteen (15) days of a request for information pertaining to qualifications, the contract may be offered and awarded for the amount of the high bid to the highest of the bidders who is qualified, responsible, and willing to accept the contract.

LOG EXPORT AND SUBSTITUTION: All timber sales, including timber from Federal rights-of-ways, shall be subject to the restrictions relating to the export and substitution of unprocessed timber from the United States in accordance with P.L. 94-165 and 43 CFR 5400 and 5420, as amended.

LOG EXPORT AND SUBSTITUTION RESTRICTIONS: Excepting Port-Orford-cedar, all timber offered for sale hereunder is restricted from export from the United States in the form of unprocessed timber and is prohibited from being used as a substitute for exported private timber. The BLM has revised the log export restrictions special provision to reduce the log branding and painting requirements. The new requirements include branding of one end of all logs with a scaling diameter of over 10 inches. All loads of 11 logs or more, regardless of the diameter of the logs, will have a minimum of 10 logs branded on one end. All logs will be branded on loads of 10 logs or less. One end of all branded logs will be marked with yellow paint. At the discretion of the Contracting Officer, the Purchaser may be required to brand and paint all logs. The Purchaser shall bear any increased costs for log branding and painting.

CONTRACT MODIFICATION, SUSPENSION OR TERMINATION: A revised Special Provision has been added to the contract which enables the Contracting Officer to suspend the contract to facilitate protection of certain plant or animal species, and/or to modify or terminate the contract when necessary to: (1) Comply with the Endangered Species Act or to prevent incidental take of northern spotted owls in accordance with management direction in the Record of Decision (ROD) and Resource Management Plan (RMP), or; (2) Comply with a court order, or; (3) Protect species which were identified for protection through survey and manage and/or protection buffer standards and guidelines or management direction established in the ROD and RMP.

ADDITIONAL INFORMATION concerning this timber sale tract is available at the above District Office. A copy of the timber sale contract is also available for inspection at the District Office. The prospectus for this/these sale(s) is also available online at: <https://www.blm.gov/programs/natural-resources/forests-and-woodlands/timber-sales>. The prospectus includes maps and tables that cannot be made Section 508 compliant. For help with its data or information, please contact the Northwest Oregon District Office at 503-375-5646.

TIMBER SALE NOTICE

NORTHWEST OREGON DISTRICT  
MARYS PEAK FIELD OFFICE  
ALSEA-RICKREALL MASTER UNIT

SALE DATE: August 28, 2024

CONTRACT NO. ORN02-TS-2024.0203: HUMBARD’S: Lump Sum  
POLK COUNTY, OREGON: O&C: ORAL AUCTION: BID DEPOSIT REQUIRED: \$74,400.00

All timber designated for cutting on: SW¼NE¼, W½, Section 11, T. 8 S., R. 8 W., Willamette Meridian.

**THIS TIMBER SALE HAS BEEN CRUISED BASED UPON EASTSIDE SCRIBNER MEASURE.**

Minimum bid figures shown by species are dollars per thousand board feet (MBF).

The minimum bid increment will be \$0.10 per MBF.

Approx. No. Merchantable Trees	Est. Vol. MBF 32' Log	Species	Est. Vol. MBF 16' Log	Appraised Price Per MBF	Estimated Volume Times Appraised Price
5,913	3,664	Douglas-fir	4,543	\$135.10	\$613,759.30
1,780	1378	Noble fir	1,666	\$46.40	\$77,302.40
3,836	941	Western hemlock	1,206	\$43.70	\$52,702.20
<b>11,529</b>	<b>5,983</b>	<b>Totals</b>	<b>7,415</b>		<b>\$743,763.90</b>

\*Minimum Stumpage values were used to compute the Appraised Price/MBF (10% of Pond Value)

LOG EXPORT AND SUBSTITUTION RESTRICTIONS: All timber offered for sale hereunder is restricted from export from the United States in the form of unprocessed timber and prohibited from substitution of exported private timber.

CRUISE INFORMATION: The timber volumes were based on variable plot cruise in the Regeneration Harvest Areas for estimated board foot volumes of trees in 16-foot logs. Approximately 0% of the total sale volume is salvage material. With respect to merchantable trees of all species; the average tree is 23.7 inches DBHOB; the average log contains 137 bd. ft.; the total gross volume is approximately 8,106 MBF; and 91% recovery is expected.

CUTTING AREA: Two units totaling approximately 152 acres shall be Regeneration Harvest. Acres shown on Exhibit A have been computed using a Trimble R1 Global Positioning System receiver. Acreage was calculated based on Global Positioning System traverse procedures including differential correction.

DURATION OF CONTRACT: Contract length will be 36 months for cutting and removal of timber.

LOCATION: The Humbard’s Timber Sale is located approximately nine (9) air miles west of Falls City, Oregon. From Falls City, drive west out Mitchell Street approximately three and a half (3.5) miles to a locked gate. Drive approximately six and a half (6.5) miles down the Black Rock mainline and turn left onto S-line / BLM road 8-8-12.0. Continue on S-line / BLM road 8-8-12.0, through a locked gate, for approximately one (1.0) mile to the sale area. See general vicinity map and Exhibit E for details.

**\*NOTE: Access to the sale is through locked gates. Prospective bidders may obtain a BLM combination from Andy Frazier @ (503) 315-5979.**

ACCESS AND ROAD MAINTENANCE: Access is provided on Weyerhaeuser Company and Bureau of Land Management controlled roads. In the use of Weyerhaeuser Company controlled roads – Weyerhaeuser Company maintenance, the Purchaser shall enter into a license agreement with Weyerhaeuser Company and pay to Weyerhaeuser Company a road use fee of twenty-two thousand two-hundred forty-five and 00/100 dollars (\$22,245.00), a road maintenance obligation of fifty-eight thousand seven hundred fifty-two and 79/100 dollars (\$58,752.79) and a road maintenance obligation for rockwear of forty-nine thousand nine hundred thirty-nine and 87/100 dollars (\$49,939.87), and carry liability insurance with limits of \$1,000,000/\$1,000,000/1,000,000.

In the use of Bureau of Land Management controlled roads – Purchaser Maintenance, the Purchaser will be required to perform maintenance on approximately 3.27 miles of road. The Purchaser shall pay the Government a road maintenance obligation for rockwear of five thousand three hundred eleven and 45/100 dollars (\$5,311.45) for timber and mineral haul associated with the contract.

Purchaser maintenance shall include frequent blading and shaping of road surface; ditch, culvert, and catch basin cleaning; removal of minor slides and other debris. Roads shall be left in a condition to withstand adverse weather at the end of the seasonal operations.

ROAD CONSTRUCTION AND RENOVATION: The purchaser will be required to do all work set forth below. The purchaser shall supply all materials unless otherwise indicated.

1. Construction:

P5, Station 0+00 – Station 3+56, 16-foot subgrade with 2-foot ditch  
Excavation; Grading and compacting; erosion control; Surfacing – Aggregate surface course, depth 6 inches, useable width 14 feet

P6, Station 0+00 – Station 5+28, 16-foot subgrade with 2-foot ditch  
Excavation; Grading and compacting; culvert installation; erosion control; Surfacing – Aggregate surface course, depth 6 inches, useable width 14 feet

P7, Station 0+00 – Station 1+65, 16-foot subgrade with a 2-foot ditch  
Excavation; Grading and compacting; erosion control; Surfacing – Aggregate surface course, depth 6 inches, useable width 14 feet

2. Renovation:

8-8-11.1, MP 0.00 – 0.32, 16-foot subgrade with 2-foot ditch  
Roadside brushing; grading and compacting; erosion control; Surfacing – Aggregate surface course, depth 6 inches, useable width 14 feet

8-8-11.2, MP 0.00 – 0.21, 16-foot subgrade with 2-foot ditch  
Roadside brushing; culvert installation; grading and compacting; erosion control; Surfacing – Aggregate surface course, depth 6 inches, useable width 14 feet

8-8-11.3, MP 0.00 – 0.13, 16-foot subgrade with 2-foot ditch  
Roadside brushing; grading and compacting; erosion control; Surfacing – Aggregate surface course, depth 6 inches, useable width 14 feet

8-8-11.4, MP 0.00 – 0.45, 16-foot subgrade with 2-foot ditch  
Roadside brushing; grading and compacting; erosion control; Surfacing – Aggregate surface course, depth 6 inches, useable width 14 feet

8-8-11.5, MP 0.00 – 0.09, 16-foot subgrade with 2-foot ditch  
Roadside brushing; grading and compacting; erosion control; Surfacing – Aggregate surface course, depth 3 inches, useable width 14 feet

8-8-11.6, MP 0.00 – 0.08, 16-foot subgrade with 2-foot ditch  
Roadside brushing; grading and compacting; erosion control; Surfacing – Aggregate surface course, depth 3 inches, useable width 14 feet

8-8-11.7, MP 0.00 – 0.23, 16-foot subgrade with 2-foot ditch  
Roadside brushing; grading and compacting; erosion control; Surfacing – Aggregate surface course, depth 6 inches, useable width 14 feet

8-8-11.8, MP 0.00 – 0.31, 16-foot subgrade with 2-foot ditch  
Roadside brushing; culvert installation; grading and compacting; erosion control; Surfacing – Aggregate surface course, depth 6 inches, useable width 14 feet

8-8-12, MP 1.23 – 2.95, 16-foot subgrade with 2-foot ditch  
Roadside brushing; culvert installation; grading and compacting; erosion control; Surfacing – Aggregate surface course, depth 6 inches, useable width 14 feet

3. Estimated Quantities:

Clearing and grubbing  
1.31 acres

Excavation  
1,877 cubic yards of common

Culvert and Flume:  
45 feet of 24-inch CMP  
170 feet of 24-inch CPP  
45 feet of 24-inch CPP downspout

Aggregate Material:

Quantity:	Description:
1,504 cubic yards	3-inch crushed rock
5,353 cubic yards	1 ½ inch crushed rock

Miscellaneous

Brushing 8.59 acres  
Soil stabilization 3.49 acres  
Blading 3.54 miles

Rock Source: Dalton, or source that meets specs and is approved by the Authorized Officer.

Special Attention Items:

Snag Creation (Sec. 44.e.)  
Fuels/Logging Residue Reduction (Sec. 44.w.)

**SEASONAL RESTRICTION MATRIX**

Activity	Jan	Feb	Mar	Apr	May	June	July	Aug	Sept	Oct	Nov	Dec
Road Construction												
Road Renovation												
In-Stream Work Period												
Ground-based Yarding (tractor)												
Skyline Yarding (cable)												
Hauling: Logs, Aggregate Surface												
Generally allowed												
Generally not allowed – or restriction applies												

TIMBER SALE CONTRACT SPECIAL PROVISIONS

Sec. 43.

RESERVED

- a. All timber on the Reserve Area, and all trees painted yellow and posted which are on or mark the boundaries of the Reserve Area, as shown on Exhibit A.
- b. All trees painted with yellow paint above and below stump height located on the Regeneration Harvest Area, as shown on Exhibit A.
- c. All snags and downed logs greater than twenty (20) inches diameter on the small end and greater than twenty (20) feet in length on the Regeneration Harvest Area, as shown on Exhibit A, which do not present a safety hazard as determined by the Authorized Officer. All snags and downed logs cut or moved for safety reasons shall be retained on site.
- d. All trees on the Regeneration Harvest Area, as shown on Exhibit A, less than seven (7) inches DBH. All dogwood, cherry, chinkapin, madrone, western white pine, Sitka spruce and Pacific yew.
- e. All trees tagged with a yellow SEED TREE tag in the Regeneration Cut areas, as shown on Exhibit A. These trees are selected as genetically superior trees and are specially valued as a component of the tree improvement program. Any damage to such reserve trees caused by the Purchaser shall be charged for on the basis of the total loss to the Government including any loss in value as a superior seed source.

Sec. 44. Special Provisions

LOGGING

- a. Before beginning the operations on the Contract Area for the first time or after a shutdown of seven (7) or more days, the Purchaser shall notify the Authorized Officer in writing of the date they plan to begin operations. The Purchaser shall also notify the Authorized Officer in writing if he intends to cease operations for any period of seven (7) or more days.
- b. Prior to the commencement of operations, the Purchaser shall obtain from the Authorized Officer written approval of a written operations and logging plan commensurate with the terms and conditions of the contract, which shall include measures needed to ensure protection of the environment and watershed. A pre-work conference between the Purchaser's authorized representative and the Authorized Officer must be held at a location designated by the Authorized Officer before the logging plan will be approved. All logging shall be done in accordance with the plan.
- c. Excessive damage to reserve timber, as determined by the Authorized Officer, will result in suspension of operations until mitigation measures are in place to prevent further damage as approved by the Authorized Officer.

d. No trees may be felled, yarded, decked, or loaded in or through the Reserve Area except where explicitly allowed, as shown on Exhibit A, or adjacent private land. Trees will be directionally felled to lead for skidding and skyline yarding to minimize ground disturbance and entry into the Reserve Area. Tops, limbs, and other logging debris entering the Reserve Area from felling operations shall be pulled back into the Regeneration Harvest Area shown on Exhibit A, unless expressly authorized by other provisions of this contract.

e. Within Regeneration Harvest Area and Reserve Area, as shown on Exhibit F, approximately one hundred seventy-five (175) trees designated for snag creation painted with a yellow "S" above and below stump height, shall be either Base-Girdled, High-Girdled, or Topped using the following general specifications. Approximately one-third of the trees to be treated shall be High-Girdled. Approximately one-third of the trees to be treated shall be Base-Girdled. Approximately one-third of the trees to be treated shall be Topped.

1. High-girdled – girdling height of live trees will vary by stand age and should range from 50-120 feet, or the top-third of the tree. Trees high-girdled shall retain 15-25 live limbs that are at least 5 feet in length below the girdled site. All cuts will completely sever the cambium, but not exceed  $\frac{1}{2}$  inch depth into the wood of the tree. High-girdled trees shall be marked with high visibility pink glo-type flagging around the bole at DBH and two pieces of flagging tied to a branch, or bole, directly below the girdling site.

2. Base-girdled – girdle site height shall be at or below DBH. All cuts will completely sever the cambium, but not exceed  $\frac{1}{2}$  inch depth into the wood of the tree. All cuts will be free of sawdust and debris. Girdled trees shall be marked with high visibility pink glo-type flagging around the bole at DBH.

3. Topped - topping height of live trees will vary by stand age and should range from 50-120 feet, or the top-third of the tree. Trees topped shall retain 15-25 live limbs that are at least 5 feet in length below the topped site. Topped trees shall be marked with high visibility pink glo-type flagging around the bole at DBH.

f. No ground-based yarding shall be conducted on the Regeneration Harvest – Ground-based Yarding area, as shown on Exhibit A, between October 15 of one calendar year and May 15 of the following calendar year, both days inclusive, or during any period of wet soil conditions as determined by the Authorized Officer.

g. In all Harvest Areas – All yarding shall be done by equipment capable of transporting the leading end of logs clear of the ground and operated entirely on designated skid roads and/or skyline corridors. Before felling and yarding any timber, except road right-of-way timber, the Purchaser shall locate designated skid trails and/or skyline corridors as follows:

1. Mark the location of designated skid roads and/or skyline corridors on the ground in a method approved by the Authorized Officer.



2. Space designated skid roads and/or skyline corridors at a minimum of one-hundred and fifty (150) feet apart unless otherwise agreed to in writing by the Authorized Officer.

3. Limit width of skid roads to a maximum of twelve (12) feet.

4. Obtain approval from the Authorized Officer of the location of all designated skid roads and/or skyline corridors.

5. Ground-based operations are limited to slopes of thirty-five (35) percent or less. Ground-based operations may be approved on slopes up to fifty (50) percent when using specialized equipment, operating on previously constructed skid trails, or accessing isolated areas over steep pitches. Existing skid roads should be used to the greatest extent possible and be located perpendicular to the slope to minimize road cutting.

6. In Yarding Allowed in Reserve Area, as shown on Exhibit A, all yarding shall be done by equipment capable of transporting the leading end of logs clear of the ground and operated entirely on designated skid roads and/or skyline corridors. All trees cut in Reserve Area are to remain onsite. The use of designated skyline yarding corridors or ground-based yarding skid trails shall be necessary when yarding through the Reserve Area. The designated corridors shall be approved by the Authorized Officer prior to yarding through the Reserve Area.

h. At all landings in the sale area, all non-merchantable logs more than eight (8) inches in diameter at the large end and exceeding eight (8) feet in length shall be decked at a location designated by the Authorized Officer. If a log or piece of log meeting or exceeding the above specifications is bucked and left in place, all portions of that log shall be yarded and decked at the designated location.

#### ROAD CONSTRUCTION, RENOVATION, IMPROVEMENT, MAINTENANCE AND USE

i. The Purchaser shall construct approximately 0.20 miles of road and renovate or improve approximately 3.54 miles of road in strict accordance with the plans and specifications shown on Exhibit C, which is attached hereto and a made a part hereof.

j. Any required road construction, improvement, or renovation shall be completed and accepted prior to the removal of any timber, except right-of-way timber, over that road.

k. No road renovation, improvement, or construction shall be conducted on the Contract Area, as shown on Exhibit A, between November 1 of one calendar year and April 30 of the following calendar year, both days inclusive, or during other periods of wet soil conditions as determined by the Authorized Officer.

l. No instream work shall be conducted on the Contract Area shown on Exhibit A between September 1 of one calendar year and June 30 of the following calendar year, both days inclusive, or during other periods of wet conditions as determined by the Authorized Officer.

m. The Purchaser is authorized to use the roads shown on Exhibit E for the removal of Government timber sold under the terms of this contract and the hauling of rock as required in Exhibit C, provided that the Purchaser pay the required maintenance obligation for road maintenance and rockwear described in Sec. 44.n. Any road shown on Exhibit E and requiring improvement or renovation in Exhibit C of this contract, shall be maintained by the Purchaser until receiving written acceptance of the improvement or renovation from the Authorized Officer.

n. The Purchaser shall pay the Government a road maintenance obligation for rockwear of five thousand three hundred eleven and 45/100 dollars (\$5,311.45) for the transportation of timber included in the contract area for the use of Purchaser maintained roads. If the total road maintenance obligation for rockwear does not exceed five hundred and 00/100 dollars (\$500.00), the Purchaser shall pay such amount in full prior to use of such roads. If the total road maintenance obligation for rockwear exceeds five hundred and 00/100 dollars (\$500.00), the Authorized Officer shall establish an installment schedule of payments of the maintenance obligation for rockwear.

o. In the use of Road No's 8-8-11.1, 8-8-12, and 8-7-23.0 the Purchaser shall comply with the conditions of Right-of-Way and Road Use Agreement No. S-805, between the United States of America and Weyerhaeuser Company. This document is available for inspection at the Northwest Oregon District Office. These conditions include:

1. Payment of a road use obligation of twenty-two thousand two hundred forty-five and 00/100 dollars (\$22,245.00) to Weyerhaeuser Company, payable at the time indicated in the License Agreement.
2. Payment of a road maintenance obligation of fifty-eight thousand seven hundred fifty-two and 79/100 dollars (\$58,752.79) and a road maintenance obligation for rockwear of forty-nine thousand nine hundred thirty-nine and 87/100 dollars (\$49,939.87) to Weyerhaeuser Company, payable at the time indicated in the License Agreement.
3. Prior to the use of said roads, the Purchaser shall furnish the Authorized Officer a properly signed copy of the executed License Agreement.
4. Default by the Purchaser of said Right-of-Way and Road Use Agreement, or any License Agreement executed pursuant thereto, for failure to pay appropriate road use fees shall be considered a violation of this contract. The amount of unpaid fees shall be considered as the amount of damage suffered by the Government as a result of the violation of this provision.

p. The Purchaser shall perform any required road repair and maintenance work on the roads identified as Purchaser maintenance, under the terms of Exhibit D, Road Maintenance Specifications, of this contract, which is attached hereto and made a part hereof.

q. The Purchaser agrees that if they elect to use any other private road, which is the subject of a Right-of-Way agreement with the Government for the removal of Government timber sold under the terms of this contract, Purchaser shall request and agree to the modification of this contract to provide for such use and for allowances for amortization of the Government's shares of the capital investment of any such road.

r. With the prior written approval of the Authorized Officer, the Purchaser may arrange for cooperative maintenance with other users of roads included in Exhibit D and E; provided, that such cooperative arrangement shall not relieve the Purchaser of his liability for the maintenance and repair of such roads resulting from wear or damage, in accordance with this contract. The Purchaser shall furnish the Authorized Officer a copy of any cooperative maintenance agreements entered into with other users of these roads.

s. The Purchaser shall be required to secure written approval to use vehicles or haul forest products and equipment over Government owned or controlled roads when such vehicles or equipment exceeds the maximum allowable weights or dimensions established by the State for vehicles operating without a permit or if vehicles meet allowable non-permitted State vehicle weights, but the haul route crosses a structure or segment of road that is posted for reduced weights. The Purchaser agrees to abide by any special requirements included in said written approval. Details of such equipment shall be furnished to the Authorized Officer for evaluation of load characteristics at least fifteen (15) days prior to proposed move in.

Details shall include:

- A. Axle weights when fully loaded.
- B. Axle spacing.
- C. Transverse wheel spacing.
- D. Tire size.
- E. Outside width of vehicle.
- F. Operating speed.
- G. Frequency of use.
- H. Special features (e.g., running tracks, overhang loads, etc.).

The Purchaser shall be responsible for repair of any damage to roads or structures caused by the use of overweight or over-dimension vehicles or equipment: (1) without written approval; (2) in violation of the conditions of a written approval; or, (3) in a negligent manner. The amount of actual damage shall be determined by the Authorized Officer following a technical inspection and evaluation.

ENVIRONMENTAL PROTECTION

t. In addition to the requirements set forth in Sec. 26 of this contract, the Purchaser shall complete grass seeding on exposed soil on all skyline roads, ground-based skid roads, landings, and any other exposed soil caused by contract obligations as directed by the Authorized Officer. Grass seed and suitable equipment to apply seed shall be furnished by the Purchaser.

Seed to be supplied shall meet the following requirements:

<u>SPECIES</u>	<u>RATE</u>
Red Fescue ( <i>Festuca rubra</i> )	100%
Oregon Certified Seed (Blue Tag)	
Purity	97% minimum
Germination	85% minimum
Noxious Weed Content	None (Tested: None Found)

The Purchaser shall apply grass seed uniformly on the designated areas at a rate equal to ten (10) pounds per acre. Evidence of seed certification shall be furnished to the Authorized Officer prior to application. Grass seed which has become wet, moldy, or otherwise damaged shall not be provided.

u. In addition to the requirements set forth in Sec. 26 of this contract, in order to reduce or prevent the spread of noxious weeds to BLM lands, all road construction, piling, and ground-based logging equipment including loaders shall be cleaned of all plant parts and soil prior to entry onto BLM lands. Equipment shall be inspected by the Authorized Officer at a site approved by the Authorized Officer to verify that the equipment had been reasonably cleaned prior to entry onto BLM lands.

FIRE PREVENTION

v. Primarily for purposes of fire prevention and control, the Purchaser shall, prior to the operation of power-driven equipment in construction or logging operations under this contract during the fire season or periods of fire danger, prepare a fire prevention and control plan to the satisfaction of the Authorized Officer. Purchaser shall take such measures for prevention and suppression of fire on the contract area and other adjacent Government lands used or traversed by Purchaser in connection with operations as are required by applicable laws and regulations. However, when in the opinion of the Authorized Officer, weather and other conditions affecting fire incidence and control make special precautions necessary to protect the contract area and said Government lands, Purchaser shall take such additional or other fire prevention and control measures as may be required by the Authorized Officer. The Purchaser shall comply with Oregon Department of Forestry Industrial Fire Precaution Level (IFPL) I Fire Season requirements. At IFPL II and III, additional fire prevention and control provisions may be added as determined by the Authorized Officer and specified in written instructions to the Purchaser to mitigate dry fuel and weather conditions.

### LOGGING RESIDUE REDUCTION

w. In addition to the requirements of Sec. 15 of this contract, and notwithstanding the Purchaser's satisfactory compliance with State laws and regulations regarding offsetting or abating the additional fire hazard created by this operation and the States willingness to release the Purchaser from liability for such hazard, the Purchaser shall remain responsible to the Government for performance of the following hazard reduction measure(s) required by this contract: Perform logging residue reduction and site preparation work on approximately forty two (42) acres of harvest area located within harvest units. The required work shall consist of any treatment or combination of treatments, as determined by the Authorized Officer and specified in writing by the Contracting Officer. The number of acres of each treatment shall be determined by the Authorized Officer. Prior to commencement of any operation under this Section of the contract, a slash disposal and pre-work conference between the purchaser's representative and the Authorized Officer must be held at a location designated by the Authorized Officer. The number of acres of each treatment shall be determined by the Authorized Officer. All slash disposal shall be done in accordance with the plans developed at this pre-work conference. Slash, as defined for this section, shall mean all material (brush, limbs, tops, unmerchantable stems, and chunks) severed or knocked over as a result of purchaser's operations under the terms of this contract.

1. Excavator pile and burn slash within ground-based portion of Regeneration Harvest Area from skid trails and within 25 feet of all roads in harvest areas. Slash shall be piled by an excavator equipped with a hydraulic thumb. Finished piles shall be tight and free of dirt.
  - a. Unmerchantable logs greater than six (6) inches on the small end shall be left in place, or positioned so that they will not be burned.
  - b. Machine piles shall be located as far as possible from snags or unit boundaries to minimize damage.
  - c. Machine piles shall be kept free of dirt and other non-wood debris and constructed as compactly as possible. There should be an adequate supply of finer fuels located within and under the covered area of the pile to ensure ignition of the larger fuels.
  - d. A minimum 10-foot by 10-foot cover of four (4) mil polyethylene shall cap each machine pile to maintain a dry ignition point. The cover shall be firmly fixed to each pile to hold it in place. Plastic shall be held in place with woody debris or tied with rope or twine. The plastic must be secured so that it is held in place during strong wind conditions. The Purchaser is required to furnish the covering materials. Covering shall be completed as directed by the Authorized Officer.
  - e. Machine piling equipment would travel on previously used skid trails during dry soil conditions. In areas inaccessible from designated skid trails

where the slope is less than 35 percent, machine piling equipment would be allowed one pass over a slash mat.

f. Cutting Areas shall be piled during the same season that they are logged.

2. Pile and burn landing slash within thirty (30) feet of the edge of each landing, all tops, broken pieces, limbs and debris more than one (1) inch in diameter at the large end and longer than three (3) feet in length shall be piled within fifteen (15) days of completion of hauling logs from that landing. Landing piles shall be kept free of dirt and located adjacent to roads at least twenty (20) feet from any Reserve Tree and/or as directed by the Authorized Officer. Upon completion of landing piling, the Purchaser shall prepare the landing piles for burning by securely covering each landing pile with four (4) mil. thick polyethylene plastic film at least 10 feet wide. Landing piles shall be covered sufficiently to allow for ignition in wet conditions as approved by the Authorized Officer. The plastic shall be oriented southwest to northeast. Pieces of burnable material shall be placed on top of the plastic to secure it from moving and to prevent it from blowing off during strong wind episodes. The Purchaser is required to furnish the covering materials. The timing of this covering work shall be in accordance with instructions from the Authorized Officer. No landing debris shall be dozed off the landing and covered with dirt. Debris which has been buried and is determined to be the source of holdover fire shall be excavated by the Purchaser, at the Purchaser's expense, with a tractor and/or hydraulic excavator as directed by the Authorized Officer. If the structure of the landing piles will not permit adequate consumption of piled debris by burning, the Purchaser shall re-pile them at the direction of the Authorized Officer.

x. Notwithstanding the provisions of Sec. 15 of this contract, the Government shall assume all obligations for disposal or reduction of fire hazards created by Purchaser's operations on Government lands, except for burning and mop-up assistance as required herein and measures required in Section 44.w. The Purchaser shall, under supervision of the Authorized Officer or designated representative, assist in preparing units for burning, burning, mop-up, and patrol by furnishing, at the Purchaser's own expense, the services of personnel and equipment on each unit as shown below:

1. For Igniting, Burning, Mop-up of Piles on Units:

a. One work leader(s) Firefighter Type 1 (FFT1) qualified according to National Wildfire Coordinating Group (NWCG) Wildland Fire Qualifications System guide, PMS 310-1) to supervise crew and equipment operations, and to serve as Purchaser's representative.

b. Five-person crew Firefighter Type 2 (FFT2) qualified according to National Wildfire Coordination Group (NWCG) Wildland Fire Qualifications System guide, PMS 310-1, with sufficient fuel for burning, six (6) drip torches, one (1) power saw, and one (1) backpack pump, one (1) tool for each crew member.

c. The crew shall arrive on the project area with radios capable of inter-crew communications and communication with a BLM representative at a ratio of one (1) radio per every five (5) crewmembers.

d. All ignition and mop-up personnel will be directly supervised by a BLM representative.

Aircraft and pilots used for Logging Residue Reduction or the suppression of escaped fires from Logging Residue Reduction operations, shall be acquired from a list of aircraft and pilots approved (i.e., carded for these specific activities) by the Office of Aircraft Services or the U.S. Forest Service. This list is available from BLM District Offices upon request.

All listed personnel shall be physically fit, experienced and fully capable of functioning as required. In addition, all listed personnel shall be qualified according to the National Wildfire Coordinating Group (NWCG) Wildland Fire Qualification System Guide, PMS-310-1 and provide documentation of these qualifications. On the day of ignition all listed personnel shall be fluent in speaking and understanding English, clothing shall consist of long pants and long sleeved shirts and be of approved aramid fabric (Nomex™ or equivalent), as well as being free of diesel fuel oil. All personnel shall wear lug sole boots with minimum eight (8) inch tall uppers that provide ankle support, approved hardhats and leather gloves. Personnel who do not meet these requirements or do not have proper clothing and personal protective equipment (PPE) will not be allowed to participate. All listed tools and equipment shall be in good usable condition. All power-driven equipment shall be fully fueled and available for immediate use. During periods of use under this subsection, the Purchaser shall provide fuel and maintenance for all such power-driven equipment.

Except as provided hereafter for fire escapement, the Purchaser shall continue the required assistance in mop up on each cutting unit shown on Exhibit A for seventy-two (72) hours, as directed by the Authorized Officer within a five (5) day period commencing at 8:00 a.m. the day following the completion of ignition in that unit, or until released from such service by the Government, whichever occurs first.

In event of a fire escapement, the Purchaser's personnel and equipment shall, under supervision of the Authorized Officer, take action to control and mop up the escaped fire until released from such service by the Government. If it becomes necessary to use furnished personnel and equipment for the suppression of a fire which escapes from the prescribed fire area for a period beyond the remainder of the day in which the fire escapes, then the Government shall, at its option: (1) reimburse the Purchaser for such additional use of personnel and equipment at wage rates shown in the current Administratively Determined Pay Rates for the Western Area and at equipment rates shown in the current Oregon-Washington Interagency Fire Fighting Equipment Rental Rates schedule until the Purchaser is released from such service by the Government; or (2) release the Purchaser from additional suppression work and assume responsibility for suppressing the escaped fire.

In situations where an escaped fire is controlled and contained by an adequate fire break (i.e., trail, road, stream, rock formation, etc.), the Government may permit the Purchaser to remove personnel for that day; provided that all mop up work on the escaped fire is included with mop up work on the prescribed fire area. In such an event, the Purchaser must sign a statement of agreement to complete mop up work on all escaped fire areas concurrently with mop up work on the prescribed fire area.

In case of injury to personnel or damage to equipment furnished as required by this subsection, liability shall be borne by the Purchaser, unless such injury or damage is caused by Government negligence.

Time is of the essence in complying with this provision. In the event the Purchaser fails to provide the personnel and equipment required herein, the Purchaser shall be responsible for all additional cost incurred by the Government in disposing of slash including but not limited to the wages and other costs of providing federal employees and others as substitute labor force, the cost of providing substitute equipment and appropriate additional overhead expenses. If the Purchaser's failure results in a deferral of burning and new conditions necessitate additional personnel and equipment to accomplish the planned burn, the Purchaser also shall be responsible for such additional costs.

#### LOG EXPORT RESTRICTION

y. Unless otherwise authorized in writing by the Contracting Officer, the Purchaser shall brand clearly and legibly one end of all logs with a scaling diameter (small end inside bark) of over ten (10) inches, prior to the removal of timber from the contract area. All loads of eleven (11) logs or more will have a minimum of ten (10) logs clearly and legibly branded on one end regardless of the diameter of the logs. All logs will be branded on loads of ten (10) logs or less. One end of all branded logs to be processed domestically will be marked with a three (3) square inch spot of highway yellow paint. The Purchaser will stop trucks for accountability monitoring at mutually agreed upon locations when notified by the Authorized Officer.

If multiple trailers (mule trains) are used, each bunked load shall be considered an individual load, and these guidelines will apply to each bunked load. If a flatbed stake trailer is used, each bundle will be treated as a separate load.

At the discretion of the Contracting Officer, the Purchaser may be required to brand and paint all logs. Any increased costs for log branding and painting shall be the responsibility of the Purchaser.





**TIMBER SALE CONTRACT MAP - ORN02-TS-2024.0203**

T. 8 S., R. 8 W., Section 11 W.M.

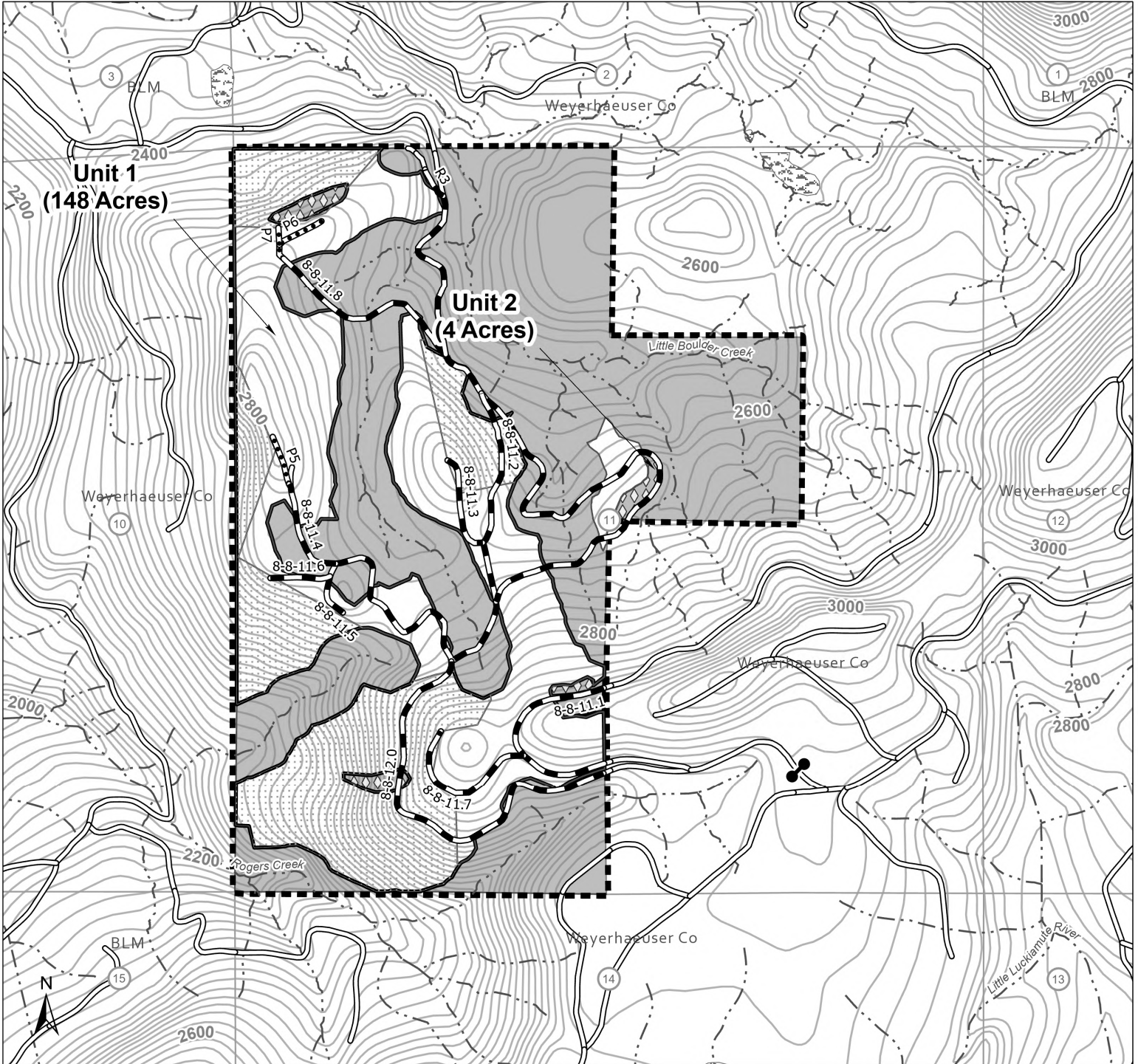

Contour Interval: 40 ft (LiDAR)

- Regeneration Harvest - Skyline Yarding
- Regeneration Harvest - Ground Based Yarding
- Boundary Contract Area
- Boundary Cutting Area
- Yarding allowed Reserve Area
- Reserve Area
- Existing Gate
- Streams
- WaterBody
- Road to be Constructed
- Road to be Renovated
- Existing Road
- IUnitLabel

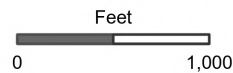

Harvest Area	152.00 Acres
Reserve Area	208.00 Acres
<b>Total Contract Area</b>	<b>360.00 Acres</b>

NOTES: Boundary of Harvest areas are painted yellow and posted. Unit acres do not include existing roads or Rights-of-Way.

UNITED STATES  
DEPARTMENT OF THE INTERIOR  
BUREAU OF LAND MANAGEMENT

**EXHIBIT B / PRE-SALE**

5450-003

Contract No.

ORN02-TS-2024.0203

Humbard's

The following estimates and calculations of value of timber sold are made solely as an administrative aid for determining: (1) adjustments made or credits given in accordance with Secs. 6, 9, or 11; (2) when payments are due; and (3) value of timber subject to any special bonding provisions. The value of timber will be determined by multiplying the value per acre as shown below, times the amount of acreage as determined by the Authorized Officer, which has been cut or removed or designated for taking. Except as provided in Sec. 2, Purchaser shall be liable for total purchase price even though quantity of timber actually cut or removed or designated for taking is less than the estimated volume or quantity shown. Cutting areas are shown on **Exhibit A**.

SPECIES	ESTIMATED VOLUME OR QUANTITY <i>(Units Specified)</i>		PRICE PER UNIT	ESTIMATED VOLUME OR QUANTITY X UNIT PRICE
Douglas Fir	4,543.0	MBF	\$135.10	\$613,759.30
Noble Fir	1,666.0	MBF	\$46.40	\$77,302.40
Western Hemlock	1,206.0	MBF	\$43.70	\$52,702.20
<b>TOTALS</b>	<b>7,415.0</b>	<b>MBF</b>		<b>\$743,763.90</b>

The apportionment of the total purchase price is as follows:

Unit 1

Douglas Fir	4,420.0 MBF	X	\$135.10	=	\$597,142.00
Western Hemlock	1,179.0 MBF	X	\$43.70	=	\$51,522.30
Noble Fir	1,626.0 MBF	X	\$46.40	=	\$75,446.40
Total	7225.0 Mbf				\$724,110.70 ÷ 148.0 acres = \$4,892.64/Acre

Unit 2

Douglas Fir	123.0 MBF	X	\$135.10	=	\$16,617.30
Western Hemlock	27.0 MBF	X	\$43.70	=	\$1,179.90
Noble Fir	40.0 MBF	X	\$46.40	=	\$1,856.00
Total	190.0 Mbf				\$19,653.20 ÷ 4.0 acres = \$4,913.30/Acre

U.S. DEPT. OF THE INTERIOR  
Bureau of Land Management  
NORTHWEST OREGON DISTRICT - OREGON  
TIMBER SALE CONTRACT

EXHIBIT C  
Table of Contents

Section	Sheet	Description
	1	Table of Contents
	2	Road Specifications
100	3-9	General
150	10	Road Plan and Detail Sheet
200	11-12	Clearing and Grubbing
300	12-14	Excavation and Embankment
400	15-18	Pipe Culverts
500	18-19	Renovation and Improvement of Existing Roads
600	19-20	Watering
1000	20-23	Aggregate Base Course – Crushed Rock
1200	23-26	Aggregate Surface Course – Crushed Rock
1700	26-27	Erosion Control
1800	27-29	Soil Stabilization
2100	29-31	Roadside Brushing
2700	31-32	Road Decommissioning
	33-37	Renovation Worklist
	38-42	Typical Detail Sheets
	43	Road Plan Map
Appendix C1	Total - 3 pages	Plan and Profile Sheets – Road Design: Rd. #P5, P6, P7

U.S. DEPT. OF THE INTERIOR  
Bureau of Land Management  
NORTHWEST OREGON DISTRICT - OREGON  
TIMBER SALE CONTRACT

Road Number and Segment	Class SN-	Length (Stations and Miles)		
		New Construction	Improvement	Renovation
8-8-11.1	16			0.32
8-8-11.2	16			0.21
8-8-11.3	16			0.13
8-8-11.4	16			0.45
8-8-11.5	16			0.09
8-8-11.6	16			0.08
8-8-11.7	16			0.23
8-8-11.8	16			0.31
8-8-12	16			1.72
P5	16	3+86		
P6	16	5+28		
P7	16		1+65	

GENERAL - 100

101 - Prework Conference(s):

A prework conference will be held prior to the start of renovation, improvement, new construction, surfacing, and mulching operations. The Purchaser shall request the conference at least 7 days prior to the time it is to be held. The conference will be attended by the Purchaser and/or his representative(s), subcontractor(s) and/or his or their representative(s) and the Authorized Officer and/or his representative(s).

The purpose will be to review the required work, exhibits and specifications, and to establish a work schedule and a list of the Purchaser's representatives and subcontractor(s).

102 - Definitions:

AASHTO - American Association of State Highway and Transportation Officials.  
Current editions of tests and specifications.

ASTM - American Society for Testing and Materials.

Base Course - Surfacing structure consisting of crushed gravel or stone, crushed sandstone, pitrun rock, bank or river-run gravels, etc., to provide support and, in the event no surface course is placed, the running surface for traffic load.

BLM - Bureau of Land Management

Borrow - Excavated material required for embankments and other portions of the work.

Culvert - A pipe, pipe-arch, arch, or box structure constructed of metal, concrete, plastic or wood which provides an opening under the roadway primarily for the conveyance of liquids, pedestrians or livestock.

Curve Widening - Widening required on inside of curves to accommodate long log and equipment hauling trucks.

Embankment - A structure of soil, aggregate, or rock material placed on a prepared ground surface and constructed to subgrade.

End Haul - Excavated material moved, other than by dozer, to an embankment or waste area to prevent sidecasting material outside of the road prism.

Excess Excavation - Material from the roadway in excess of that needed for construction of the designed roadway (waste).

Grading - Leveling to grade, shaping and smoothing of a road subgrade; the shaping of roadside ditches as to grade and contour. In some instances includes smoothing of the cut bank.

Overhaul - Distance excavated material is transported in excess of the distance included in the cost for excavation.

Pioneer Road - Temporary construction access built along the route of the project.

Piping - The process by which soil particles are washed in or through pore spaces in drains and filters or poorly compacted fill/backfill material.

Plans - The approved drawings, or exact reproductions thereof which show the locations, character, dimensions, and details of the work to be done.

Purchaser - The individual, partnership, joint venture, or corporation contracting with the Government under the terms of a Timber Sale Contract and acting independently or through their, or its agents, employees, or contractors.

Reasonably Close Conformity - Compliance with reasonable and customary manufacturing and construction tolerances where working tolerances are not specified.

Roadbed - The graded portion of the road within top and side slopes, prepared as a foundation for the pavement structure and shoulders.

Road Centerline - Longitudinal center of roadbed.

Road Improvement - Work done to an existing road which improves it over its original design standard.

Road Renovation - Work done to an existing road which restores it to its original design.

GENERAL – 100

Roadway - The portion of a road within limits of construction. Usually from the toe of the fill slope to a point where the cut slope intersects natural ground line.

Synonym - road prism.

Scarification - The process of loosening or breaking up of the surface layer of soil or road, usually to a specified depth.

Shoulder - The portion of the roadbed contiguous with the traveled way designed for accommodation of stopped vehicles, safety, and lateral support of base and surface courses.

Slope Ratio – Slope ratio equals horizontal distance: vertical distance, HD:VD

Spalls - Flakes or chips of stone.

Specifications - A general term applied to all directions, provisions, and requirements pertaining to performance of the work.

Specific Gravity - The ratio of the density of a material to the density of water obtained by weighing known volumes of both items in air. A specific gravity less than one implies that the material will float.

Structures - Bridges, culverts, catch basins, retaining walls, underdrains, flumes, splash pads, downspouts, and other project features which may be involved in the work and not otherwise classified in these specifications.

Subbase - Reinforcement of the subgrade with large particles of pitrun or crushed stone. Usually confined to roads having wet subgrades or subgrades with weak support characteristics.

Surface Course - Top layer of a road structure consisting of finely crushed gravels or asphalt designed to provide a smooth running surface for traffic load.

Subgrade - The top surface of a roadbed upon which the traveled way and shoulders are constructed.

Timber - Standing trees, downed trees, or logs which can be measured in board feet.

GENERAL – 100

Traveled Way - The portion of the roadbed used for the movement of vehicles, exclusive of shoulders.

Typical Cross Sections - Cross-sectional plane of a typical roadway; showing natural ground line and designed roadway in relation to cut and fill, through cut, and through fill.

Turnout - Extra widening of the roadbed at appropriate intervals on single-lane roads for passing purposes.

102a - Tests Used in These Specifications:

AASHTO T 11            Quantity of rock finer than No. 200 sieve.

AASHTO T 27            Sieve analysis of fine and coarse aggregate using sieves with square openings; gradation.

AASHTO T 96            Resistance to abrasion of small size coarse aggregate by use of the Los Angeles machine.  
This test required if requested by the Authorized Officer.

AASHTO T 99            Relationship between soil moisture and density of soil.  
Method A - 4" mold, soil passing a No. 4 Sieve.  
25 blows/layer & 3 layers.  
Method C - 4" mold, soil passing a 3/4 inch sieve  
25 blows/layer & 3 layers.  
Method D - 6" mold, soil passing a 3/4 inches sieve.  
56 blows/layer & 3 layers.  
This test required if requested by the Authorized Officer.

AASHTO T 210           Durability of aggregate based on resistance to produce fines.  
This test required if requested by the Authorized Officer.

103 - Compaction equipment shall meet the following requirements:

103a - Padded Drum (Tamping) Rollers. The unit shall consist of a drum with pads, be either self propelled or towed by a tractor, and capable of operating at a speed of 6 mph. The drum shall be no less than 48 inches in diameter over the pads and not less than 60 inches in width. The pads shall have a minimum height of 3 inches, and a face area of not less than 14 square inches. The weight at drum shall be no less than 8000 lb.



GENERAL – 100

- 103b - (Sheepfoot) (Tamping) rollers. A tamping roller unit shall consist of two watertight metal drums mounted in frames in such manner as to be fully oscillating, together with a tractor having sufficient weight and power under actual working conditions to pull the roller drums at a minimum speed of 2.5 miles per hour. The drums shall be no less than 60 inches in diameter and no less than 54 inches in length, measured at the drum's surface, and shall be studded with tamping feet projecting not less than 7 inches from the face of the drums.

The distance between circumferential rows of tamper feet shall be such that the diagonal distance from any foot to the nearest foot in each adjacent row shall be not more than 12 inches. The cross-sectional area of the face of each tamper foot, measured perpendicular to the axis of the stud, shall be not less than 5-1/2 square inches nor more than 8 square inches.

The weight of the tamping-roller unit shall be such as to exert a minimum pressure of 250 pounds per square inch on the ground area in contact with the tamping feet, and the roller shall be so designed that the weight may be increased to exert a pressure up to 500 pounds per square inch on the ground area in contact with the tamping feet. The ground pressure shall be determined by dividing the total weight of the roller unit, not including the weight of the tractor, by the total cross-sectional area of the tamping feet in one row of tamping feet parallel to the axis of the roller.

- 103c - Smooth-wheel power rollers. Smooth-wheel power rollers shall either be of the 3-wheel type, weighing not less than 10 tons, or of the tandem type, 2-wheel or 3-wheel, weighing not less than 8 tons. Smooth-wheel roller shall provide compression of 325 pounds per linear inch of width of rear wheels or drum.

- 103e - Grid roller. A grid roller shall consist of two or more cylindrical drums independently mounted on a common shaft in a rigid frame. Each drum shall have a minimum outside diameter of 5 feet and a minimum width of 2 feet 6 inches. The overall width of the roller exclusive of frame shall be not less than 5 feet 6 inches of which not more than 6 inches shall be used for center spacing between two roller drums. The face of the drums shall have the appearance of woven open-mesh made by interlacing bars of not less than 1-1/4 inches nor more than 1-3/4 inches diameter space spaced on 4-1/2 inches to 5-1/2 inches center. Net opening between the bars shall be not less than 3 inches nor more than 4 inches. The roller shall be so constructed that counterweights can be used to adjust the gross weight of the roller to not less than 27,000 pounds. The grid roller shall be drawn by a power unit capable of propelling the fully loaded roller through 6 inches of loose embankment material at a speed of at least 4 miles per hour.

GENERAL – 100

- 103f - Vibratory roller. The drum diameter shall be not less than 48 inches, the drum width not less than 58 inches, and have a turning radius of 15 feet or less. Vibration frequency shall be regulated in steps to 1400, 1500, and 1600 vibrations per minute (VPM), corresponding to engine speeds of 1575, 1690, and 1800 RPM. The centrifugal force developed shall be 7 tons at 1600 RPM. It shall be activated by a power unit of not less than 25 horsepower. The vibratory roller shall be self-propelled or drawn by a vehicle of sufficient horsepower to enable the unit to travel through a loose layer of material at a speed ranging from 0.9 mile to 1.8 miles per hour, as directed by the Authorized Officer.

The towing vehicle and roller or self-propelled unit meeting the above requirements shall be considered a vibratory roller unit.

- 103g - Vibratory compactor. Vibratory compactors shall consist of multiple or gang-type compacting units or pads with a minimum variable width of 2 feet. It shall be self-contained and capable of compacting material as required.
- 103h - Drum drive self-propelled vibratory grid roller. The unit shall consist of one cylindrical drum with a drum diameter of not less than 56 inches, nor more than 66 inches and the drum width shall be 84 inches. Vibration frequency shall be regulated in steps from 1200 to 1800 vibrations per minute (VPM), and the centrifugal force developed shall be at least 40,000 pounds at 1800 RPM. The vibratory grid roller shall be self-propelled and have a power unit of not less than 112 horsepower. The "grid" design shall be a herringbone or z-bar pattern around the circumference of the drum. The grid bars shall be 1 inch in height and spaced not more than 8-1/2 inches apart.
- 103i - Other. Compaction equipment approved by the Authorized Officer.
- 105 - All project activities shall meet the following BMP requirements:
- 105a - All heavy equipment shall be cleaned prior to initially entering or operating on BLM lands. The equipment shall be free of noxious weed seed, external petroleum residue, caked on dirt or grime, and other contaminants. Any leakage or contamination risk shall be corrected prior to continuing operation. An inspection by the Authorized Officer is required prior to beginning work.
- 105b - No refueling of any heavy equipment shall be done within 100 feet of standing or running water.

GENERAL – 100

105c - The Purchaser and/or his representative(s), subcontractor(s) and/or his or their representative(s) shall comply with the following Sections of this contract in connection with any operations under this contract:

Section 26 - Watershed Protection

Section 27 - Refuse Control and Disposal of Waste Materials

Section 28 - Storage and Handling of Hazardous Materials

U.S. DEPT. OF THE INTERIOR  
Bureau of Land Management  
NORTHWEST OREGON DISTRICT OFFICE - OREGON  
**150: ROAD PLAN AND DETAIL SHEET**

Sale Name Humbarb's

**EXHIBIT C**

Contract No. ORN02-TS-2024.0203

Sheet 10 of 43

Road Number	From: Mile Post	To: Mile Post	Length	Typical Section Type	Min Curve Radius	Road Width		Gradient		Clearing Width(*7)				Surfacing							REMARKS				
						Subgrade Width	Ditch Depth	Fav	Adv	Beyond		Existing Roads (*6)		Base Course				Surface Course							
										Top Cut	Toe Fill	L	R	Minimum Width	Compact Depth	Surface Type	Grading Size	Number of Lifts	Minimum Width	Compact Depth		Surface Type	Grading Size	Number of Lifts	
8-8-11.1	0.08	0.32	0.24	6	-	16'	2'	-	-	-	-	-	-	-	-	-	-	-	-	14'	6"	ASC	C	2	
8-8-11.2	0.00	0.08	0.08	6	-	16'	2'	-	-	-	-	-	-	-	-	-	-	-	-	14'	6"	ASC	C	2	
8-8-11.3	0.00	0.13	0.13	6	-	16'	2'	-	-	-	-	-	-	-	-	-	-	-	-	14'	6"	ASC	C	2	
8-8-11.4	0.00	0.45	0.45	6	-	16'	2'	-	-	-	-	-	-	-	-	-	-	-	-	14'	6"	ASC	C	2	
8-8-11.5	0.00	0.09	0.09	6	-	16'	2'	-	-	-	-	-	-	-	-	-	-	1	14'	3"	ASC	C	1	167 cu yds of 3" minus for landing pad	
8-8-11.6	0.00	0.08	0.08	6	-	16'	2'	-	-	-	-	-	-	-	-	-	-	1	14'	3"	ASC	C	1	167 cu yds of 3" minus for landing pad	
8-8-11.7	0.00	0.23	0.23	6	-	16'	2'	-	-	-	-	-	-	-	-	-	-	1	14'	6"	ASC	C	2	502 cu yds of 3" minus for landing pads	
8-8-11.8	0.00	0.31	0.31	6	-	16'	2'	-	-	-	-	-	-	-	-	-	-	-	14'	6"	ASC	C	2		
8-8-12	1.29	2.04	0.75	6	-	16'	2'	-	-	-	-	-	-	-	-	-	-	1	14'	6"	ASC	C	2	167 cu yds of 3" minus for landing pad	
-	-	-	-	-	-	-	-	-	-	-	-	-	-	-	-	-	-	-	-	-	-	-	-	-	
P5	0.00	0.07	0.07	6	-	16'	2'	-	-	-	-	-	-	-	-	-	-	1	14'	6"	ASC	C	2	167 cu yds of 3" minus for landing pad	
P6	0.00	0.10	0.10	6	-	16'	2'	-	-	-	-	-	-	-	-	-	-	1	14'	6"	ASC	C	2	167 cu yds of 3" minus for landing pad	
P7	0.00	0.03	0.03	6	-	16'	2'	-	-	-	-	-	-	-	-	-	-	1	14'	6"	ASC	C	2	167 cu yds of 3" minus for landing pad	
-	-	-	-	-	-	-	-	-	-	-	-	-	-	-	-	-	-	-	-	-	-	-	-	-	

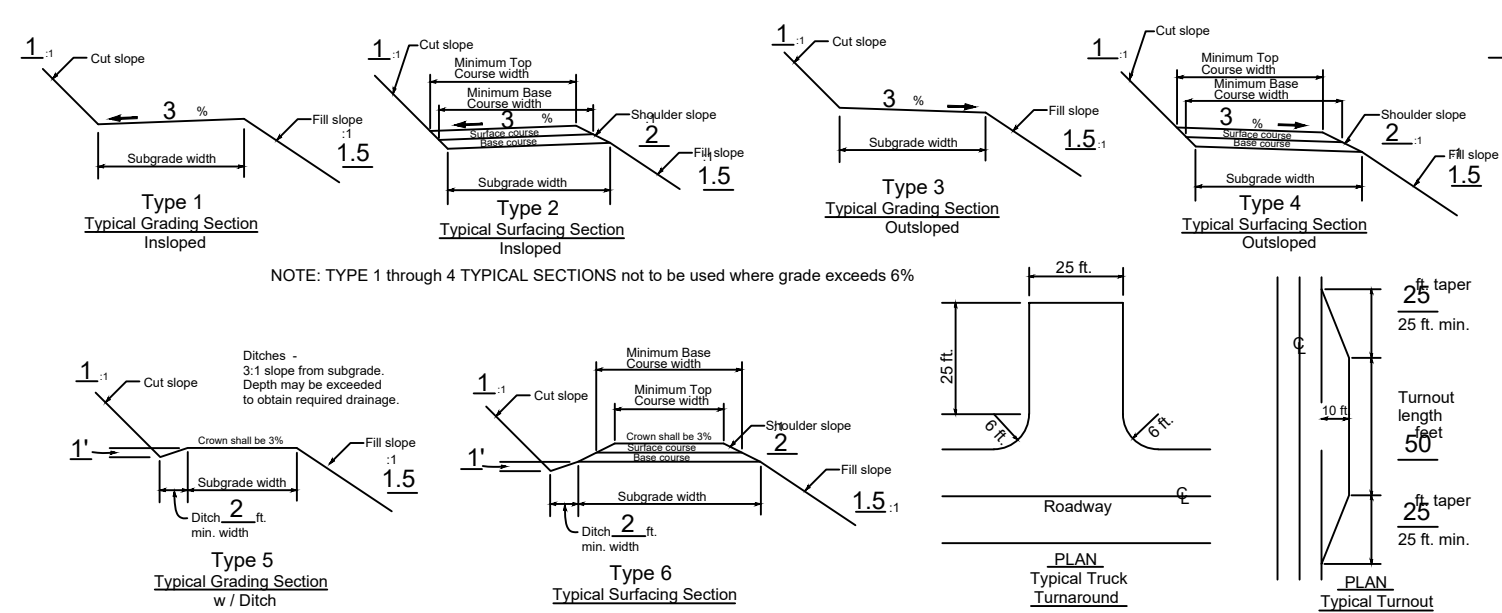

**\*NOTES**

- Extra subgrade widths**  
Add to each shoulder: 1 foot for fills of 1 to 6 feet. Widen inside or outside shoulder of tight curves as needed for log trucks to maneuver, with tires remaining on roadbed.
- Backslopes**  
Materials: Soft rock and shale 1/2:1, Slopes under 55% 3/4:1, Slopes over 55% 1:1.  
Fill slopes: Angle of repose 1:1, 1-1/2:1, 1-1/2:1.
- Surface type**  
PRR - Pit run rock, GRR - Grid rolled rock, SRN - Screened rock, JRR - Jaw run rock, ABC - Aggr. base course, ASC - Aggr. surface course, WC - Wood chips.  
Grading: C - 1 1/2" minus, D - 1" minus (surface course), E - 3/4" minus, A - 3" minus, B - 2" minus (base course), C - 3"
- Turnouts**  
Width shall be 10 feet in addition to the subgrade width, with lengths as shown on this plan, or as directed by the Authorized Officer.
- Surfacing**  
Turnouts, curve widening, and the first 50 feet of all road aprons shall be surfaced, for all road stations requiring surfacing, as listed above, and as directed by the Authorized Officer.
- Clearing width** 200  
See Section 2100 of this contract.  
As posted and painted for Right of Way, and as directed by the Authorized Officer.
- Grading (Renovation)** 500  
See Section 500
- Drainage** 400  
See Section 400  
Culvert site aggregate, as designated in Section 400 of this contract, does not fulfill any requirements as listed above for full lifts of surface or base applications.
- Compaction** 300 and 500  
See Sections 300 and 500

CLEARING AND GRUBBING - 200

- 201 - This work shall consist of clearing, grubbing, removing and disposing of vegetation, debris, surface objects, and protruding obstructions within the clearing limits in accordance with these specifications and conforming to the lines, grades, dimensions and typical cross sections shown on the plans and as staked on the ground.
- 202 - Where clearing limits have not been staked, established by these specifications or shown on the plans, the limits shall extend 4 feet back of the top of the cut slope and 4 feet out from the toe of the fill slope.
- 202a - Where clearing limits for structures have not been staked or shown on the plans, the limits shall extend 10 feet out from the outside edge of the structure.
- 203 - Clearing shall consist of the removal and disposal of trees, logs, rotten material, brush, and other vegetative materials and surface objects in accordance with these specifications and within the limits established for clearing as specified under Subsections 202, and 202a, as shown on the plans, and as staked on the ground and/or as posted.
- 203b - Standing trees and snags to be cleared shall be felled within the limits established for clearing unless otherwise authorized.
- 204 - Grubbing shall consist of the removal and disposal of stumps, roots, and other wood material embedded in the ground and protruding obstacles remaining as a result of the clearing operation and in accordance with Subsections 204a, and 204c between the top of the cut slope and the toe of the fill slope.
- 204a - Stumps, including those overhanging cut banks, shall be removed within the required excavation limits.
- 204c - On excavated areas, roots and embedded wood shall be removed to a depth not less than 6 inches below the subgrade.
- 205 - Clearing and grubbing debris shall not be placed or permitted to remain in or under road embankment sections. Such debris will, however, be permitted to remain under waste material from full-bench construction on steep side slopes.
- 210 - Disposal of clearing and grubbing debris shall be by scattering over government owned lands outside of established clearing limits in a manner acceptable to the Authorized Officer. The areas for such scattering shall have the prior approval of the Authorized Officer.

CLEARING AND GRUBBING - 200

- 210a - Disposal of clearing and grubbing debris shall be by piling on government lands outside of established clearing limits in an area and in a manner acceptable to the Authorized Officer, when accumulations are too great to scatter.
- 210b - Disposal of clearing and grubbing debris, stumps and cull logs on non-government property by scattering this material outside of clearing limits will not be permitted unless the Purchaser obtains a written permit, or other approved documentation, from the property owner on whose property the disposal is to be made. The Purchaser shall furnish the Authorized Officer a certified copy of the permit and a written release from the property owner absolving the Government from responsibilities in connection with the disposal of debris on said property.
- 212 - No grading will be permitted prior to completion and approval by the Authorized Officer of the required clearing and grubbing work, except that stump grubbing may proceed with the excavation of the road prism.
- 213 - No clearing or grubbing debris shall be left lodged against standing trees or otherwise impede tree felling on any trees within the existing stands adjacent to the road construction.

EXCAVATION AND EMBANKMENT - 300

- 301 - This work shall consist of excavating, overhaul, placement of embankments, backfilling, borrowing, leveling, ditching, grading, insloping, outsloping, crowning and scarification of the subgrade, compaction, disposal of excess and unsuitable materials, and other earth-moving work in accordance with these specifications and conforming to the lines, grades, dimensions, and typical cross sections shown on the plans.
- 302 - Excavation shall also consist of the excavation of road and landing cut sections, borrow sites, backfilling, leveling, ditching, grading, compaction, and other earth moving work necessary for the construction of the roadway in accordance with these specifications and conforming to the lines, grades, dimensions, and typical cross sections shown on the plans.
- 303 - Suitable material removed from the excavation shall be used in the formation of embankment subgrade, shoulders, slopes, bedding, backfill for structures, and for other purposes as shown on the plans.

EXCAVATION AND EMBANKMENT - 300

- 304 - Borrow shall consist of suitable material required for the construction of embankments or for other portions of the work; such material shall be obtained from sources selected by the Purchaser at his option and approved by the Authorized Officer.
- 305 - Embankment construction shall consist of the placement of excavated and borrowed materials, backfilling, leveling, grading, compaction, and other earth-moving work necessary for the construction of the roadway and landings in accordance with these specifications and conforming to the lines, grades, dimensions, and typical cross sections shown on the plans.
- 305a - Material used in the construction of embankment sections shall be free of stumps, cull logs, brush, muck, sod, roots, frozen material and other deleterious materials and shall be placed and compacted as specified.
- 305b - Embankment materials shall be placed in successive parallel layers on areas cleared of stumps, cull logs, brush, sod, and other vegetative and deleterious materials, except as provided under Subsection 204. Roadway embankments of earth material shall be placed in horizontal layers not exceeding 12 inches in depth.
- 306 - Layers of embankment, selected borrow, final subgrade, and selected roadway excavation material as specified under Subsections 305a, and 305b shall be moistened or dried to uniform optimum moisture content suitable for maximum density and compacted to full width with compacting equipment conforming to requirements of Subsections 103f, 103g and 103i.
- 306e - The final subgrade, including landings, shall be compacted to full width with compacting equipment conforming to the requirements of Subsections 103f, 103g, and 103i until visible displacement ceases.
- 308 - In the case of rock fills, placement of material in layers is not required and such material may be placed by end-dumping or other methods approved by the Authorized Officer provided that the rock shall be reasonably prevented from escaping beyond the embankment toe.
- 313 - In cut areas where solid rock is encountered at, or near subgrade, the rock shall be excavated to a minimum depth of 6 inches below subgrade elevation and the excavated area backfilled with suitable material. The backfill material shall be processed to the optimum moisture content suitable for maximum density and compacted to full width in accordance with the requirements of Subsection 306e.

EXCAVATION AND EMBANKMENT - 300

- 314 - When heavy clays, muck, clay shale, or other deleterious material for forming the roadbed is encountered in cuts at subgrade, it shall be excavated to a minimum depth of 2 feet below the subgrade elevation and the excavated area backfilled with a selected borrow material approved by the Authorized Officer. The backfill material shall be uniformly moistened or dried to the optimum moisture content suitable for maximum density in accordance with the requirements of subsection 306. Unsuitable material shall be disposed of as directed by the Authorized Officer.
- 316 - Borrow material from sources selected at the Purchaser's option shall be inspected and approved in writing by the Authorized Officer prior to placement.
- 318 - Selected borrow or selected roadway excavation material shall be uniformly spread on the roadbed in lifts not to exceed 8 inches in depth until the required thickness shown on the plans is attained.
- Each layer shall be uniformly moistened or dried to the optimum moisture content suitable for maximum density and compacted to full width in accordance with the requirements of Subsection 306.
- 320 - Ditches shall conform to the slope, grade, dimensions, and shape of the required cross section shown on the Section 150 sheet. Roots, stumps, rocks, and other projections shall be removed to form smooth, even slopes.
- 321 - Excess excavated, unsuitable, or slide materials shall not be disposed of on areas where the material will encroach on a stream course or other body of water. Such materials shall be disposed of in accordance with Subsection 321c.
- 321c - End-dumping will be permitted for the placement of excess materials under Subsection 321 in designated disposal areas or within areas approved by the Authorized Officer. Watering, rolling, and placement in layers is (not) required. Materials placed shall be sloped, shaped, and otherwise brought to a neat and sightly condition acceptable to the Authorized Officer. Exposed soils must be seeded and mulched in accordance with Section 1800 of this Contract.
- 324 - Excavated material shall not be allowed to cover boles of standing trees to a depth in excess of 2 feet on the uphill side.
- 327 - The finished grading shall be approved by the Authorized Officer in segments or for the total project. The Purchaser shall give the Authorized Officer 3 days notice prior to final inspection of the grading operations.



PIPE CULVERTS - 400

- 401 - This work shall consist of furnishing and installing corrugated-polyethylene pipe culverts Type S (CPP), or Aluminized corrugated metal pipe (CMP) and other erosion control devices in accordance with these specifications and conforming to the lines, grades, dimensions, and typical cross sections shown on the plans. Individual lengths and locations are approximate; final lengths and locations will be determined by the Authorized Officer upon installation of the appurtenance structures. Additional pipe and erosion control devices may be required at the option of the Authorized Officer, in which case a reduction in the total purchase price shall be made to offset the cost of furnishing and installing such items. Costs will be based upon the unit prices set forth in the current BLM Timber Appraisal Production Cost Schedule.
- 402 - The pipe culverts located at the following road locations:

Road No.	Sta./MP	Type	Remove	Diameter (inch)	Length (feet)	Surface Aggregate (cubic yard)	Remarks
8-8-12	1.30	CPP	18"x30'	24	30	10	
	2.38	CMP					CMP 15' Downspout
	2.61	CPP	24"x24'	24	30	10	CPP 15' Downspout
	2.75	CMP	24"x40'	24	45	10	CMP 15' Downspout and 10 Cu Yd Riprap Splash Pad
	2.83	CPP	24"x45'	24	40	10	
8-8-11.8	0.02	CPP	12"x28'	24	30	10	
	0.16	CMP	50"x50'				Remove old pipe and restore to flowline after operations are complete
P6	1+65	CPP	--	24	40	10	

PIPE CULVERTS - 400

- 402a - The aggregate listed on the above tables shall meet the requirements of Section 1000 in conjunction with the specifications in Section 150 and shall be evenly distributed and compacted within the uppermost portion of the excavation limits. This material serves as a base rock and will not fulfill the obligation of surface rock required in Section 150. That rock shall still be placed on top of this base, at the required width and depth specified in Section 150.
- 402b - At culvert installation sites where riprap and surface aggregate currently exists, conserve the material for reuse as slope armor and for base material in the upper limits of the trench backfill.
- 403 - Grade culverts shall have a gradient of from 2 percent to 4 percent greater than the adjacent road grade and shall be skewed down grade 30 degrees as measured from the perpendicular to the centerline unless otherwise specified on the plans or by the Authorized Officer.
- 405e - Corrugated-polyethylene pipe for culverts 12-inch through 36-inch diameter shall meet the requirements of AASHTO M 294.
- 406 - Coupling bands shall conform to the requirements of AASHTO M 36 and AASHTO M 218 or AASHTO M 274 with the exception of band widths and the "Hugger"-type band which shall conform to the details, dimensions, and typical diagram shown on the plans.
- 408 - Pipe culverts shall be placed on the bed starting at the downstream end with the inside circumferential laps pointing downstream and with the longitudinal laps at the side or quarter points. Coupling bands of the type required under these specifications shall be installed so as to provide the circumferential and longitudinal strength necessary to preserve the pipe alignment, prevent separation of the pipe sections, and minimize infiltration of fill material.
- 410 - Pipe shall be unloaded and handled with reasonable care. If the Authorized Officer determines any structure is damaged to the extent that it is unsuitable for use in the road construction, it shall be replaced at the Purchaser's expense.
- 411 - Trenches necessary for the installation of pipe culverts shall conform to the lines, grades, dimensions and typical diagram shown on the plans and the Culvert Installation Detail Sheets.

PIPE CULVERTS - 400

- 412 - Where ledge rock, boulders, soft, or spongy soils are encountered, they shall be excavated a minimum of 12 inches below the invert grade for a width of at least one pipe diameter or span on each side of the pipe and shall be backfilled with selected granular or fine readily compactible soil material.
- 413 - Pipe culverts shall be bedded on 1 ½" or ¾" crushed rock bed in accordance with Section 1200 gradation and having at least a depth of 4 inches. Each layer of crushed rock material for base shall be placed, processed, shaped, moistened or dried to uniform moisture content suitable for maximum compaction, and compacted to full width by compaction equipment conforming to the requirements of Subsection 103f and 103i. Foundation material shall be of uniform density throughout the length of the structure and shall be shaped to fit the pipe.
- 416 - Side-fill material for pipe culverts shall be placed within 1 pipe diameter, or a minimum of 2 feet, of the sides of the pipe barrel, and to 1 foot over the pipe with fine, readily compactible soil or granular fill material free of excess moisture, muck, frozen material, roots, sod, or other deleterious or caustic material and devoid of rocks or stones of sizes which may impinge upon and damage the pipe or otherwise interfere with proper compaction.
- 417 - Side-fill material conforming to the requirements of Subsection 416 shall be placed and compacted under the haunches of the pipe, and shall be brought up evenly and simultaneously on both sides of the pipe to 1 foot above the pipe, in layers not exceeding 8 inches in depth and 1 pipe diameter/span, or a minimum of 2 feet in width each side of, and adjacent to, the full length of the pipe barrel.
- 418 - Side fills beyond the compaction limits specified under Subsection 417 shall be compacted as specified under Section 300.
- 419 - The pipe culverts, after being bedded and backfilled as required by these specifications, shall be protected by a 2 foot cover of fill before heavy equipment is permitted to cross the drainage structures. Removal of the protection fill shall be as directed by the Authorized Officer.
- 423 - Construction of catch basins and ditch dams conforming to lines, grades, dimensions and typical diagrams shown on the plans, shall be required for grade culverts.
- 424 - Construction of splash pads conforming to lines, grades, dimensions and typical diagram shown in the plans, shall be required and at the specified locations and with riprap amounts as stated in the table in Subsection 401.

PIPE CULVERTS - 400

- 426 - Culvert markers consisting of 5-foot steel fence posts painted green with white tops, shall be furnished, fabricated, and installed by the Purchaser at the culvert inlets, as shown on the plans and as directed by the Authorized Officer.
- 427 - The Purchaser shall record culvert sizes, lengths and locations actually installed on a copy of the culvert list. This culvert list shall be furnished to the Authorized Officer.
- 428 - Remove and dispose of old culverts in a legal manner, and for any fees required. The Purchaser shall remove the old culverts from the work site prior to road acceptance.

RENOVATION OF EXISTING ROADS - 500

- 501 - This work shall consist of reconditioning and preparing the roadbed and shoulders, minor excavation and/or embankment, cleaning and shaping drainage ditches, trimming vegetation from cut and embankment slopes, and cleaning and repairing drainage structures of existing roads in accordance with these specifications and as shown on the plans.
- 501a - This work shall include the removal and disposal of slides in accordance with these specifications.
- 502 - The existing road surface shall be bladed and shaped to the lines, grades, dimensions, and typical cross sections shown on the plans at the following locations:

Road No.	From Sta./M.P.	To Sta./M.P.
8-8-11.1	0.08	0.32
8-8-11.2	0.00	0.21
8-8-11.3	0.00	0.13
8-8-11.4	0.00	0.45
8-8-11.5	0.00	0.09
8-8-11.6	0.00	0.08
8-8-11.7	0.00	0.23
8-8-11.8	0.00	0.31
8-8-12	1.23	2.95

RENOVATION OF EXISTING ROADS - 500

- 502a - Rocks larger than 6 inches in maximum dimension shall be removed from the scarified layers of the roadbed. Material so removed will not be permitted to remain on road shoulders or in ditches.
- 504 - Existing road surfaces shall be uniformly moistened or dried to the optimum moisture content suitable for maximum density and compacted to full width with equipment conforming to requirements of Subsections 103f, and 103i, until visible displacement ceases, generally 4 stations per hour.
- 506 - The inlet end of existing drainage structures shall be cleared of vegetative debris and boulders that are of sufficient size to obstruct normal stream flow. Pipe inverts shall be cleared of sediment and other debris lodged in the barrel of the pipe. The outflow area of pipe structures shall be cleared of rock and vegetative obstructions which will impede the structure's designed outflow configuration. Catch basins shall conform to the lines, grade, dimensions, and typical diagram shown on the plans.
- 508 - Vegetation encroaching on the roadbed and the drainage ditches of existing roads shall be removed by cutting and disposed of in accordance with Subsection 2100 of these specifications.
- 509 - The finished grading shall be approved by the Authorized Officer. The Purchaser shall give the Authorized Officer 3 days notice prior to final inspection of the grading operations

WATERING - 600

- 601 - This work shall consist of furnishing and applying water required for the compaction of embankments, roadbeds, backfills, base courses, surface courses, finishing and reconditioning of existing roadbeds, or for other uses in accordance with these specifications.
- 602 - Water, when needed for compaction shall be applied at the locations, in the amounts, and during the hours as directed by the Authorized Officer. Amounts of water to be provided will be the minimum needed to properly execute the compaction requirements in conformance with these specifications.
- 603 - Water trucks used in this work shall be equipped with a distributing device of ample capacity and of such design as to ensure uniform application of water on the roadbed.

WATERING - 600

- 604 - Water required under these specifications is subject to applicable State water regulations.
- 605 - The Purchaser shall secure the necessary water permits for use of water source(s) selected by the Purchaser and approved by the Authorized Officer.

AGGREGATE BASE COURSE - 1000  
CRUSHED ROCK MATERIAL

- 1001 - This work shall consist of furnishing, hauling, and placing one or more lifts of crushed rock material on roadbeds, turnouts and landings approved for placing crushed rock material, in accordance with these specifications and conforming to the dimensions and typical cross sections shown on the Section 150 plans. Material not conforming to these specifications will be rejected, and shall be removed from the road.
- 1002a - Crushed rock materials may be obtained from commercial sources selected by the Purchaser at his option and expense providing that the rock materials selected comply with the specifications in this section.
- 1003 - Crushed rock material produced from gravel shall have 2 manufactured fractured faces on 65 percent, by weight, of the material retained on the No. 4 sieve.
- 1004 - Crushed rock materials shall consist of hard durable rock fragments conforming to the following gradation requirements:

TABLE 1004  
AGGREGATE BASE COURSE  
CRUSHED ROCK MATERIAL

Percentage by Weight Passing Square Mesh Sieves  
(AASHTO T 11 & T 27)

GRADATION

Sieve Designation	A	B	C	D	F	G	H	JRR
(6) -inch	-	-	-	-	-	-	-	100
3-inch	100	-	100	-	100	-	-	-
2-inch	90-95	100	-	100	65-95	100	100	-
1½-inch	-	90-95	-	-	-	-	-	-
1-inch	45-75	50-90	-	-	-	50-85	60-90	-
¾-inch	-	-	-	-	28-70	-	-	-
½-inch	-	-	-	-	-	27-60	44-70	-
3/8-inch	-	-	-	-	-	-	-	-
No. 4	15-45	15-50	-	-	10-35	15-40	28-50	-
No. 8	-	-	-	-	-	-	20-41	-
No. 10	-	-	-	-	-	-	-	-
No. 30	-	-	-	-	5-22	8-26	9-26	-
No. 40	5-25	5-25	-	-	-	-	-	-
No. 200	2-15	2-15	-	-	3-10	3-12	3-12	-

AGGREGATE BASE COURSE - 1000  
CRUSHED ROCK MATERIAL

- 1004a - The Purchaser shall be required to take 1 sample of each 2,000 cubic yards of crushed rock material produced, using approved AASHTO sampling procedures. The Purchaser shall submit samples to a certified lab or shall perform testing for gradation requirements using ASHTO T 11 and AASHTO T 27 testing procedures. Prior to testing, each sample shall be split, making one-half of the samples with proper identification available for testing by the Authorized Officer. Each sample and the results of Purchaser testing shall be made available to the Authorized Officer within 24 hours of sampling. The Purchaser shall provide test results for the first 500 cubic yards produced prior to commencing production crushing and hauling.
- 1008 - If additional binder or filler is necessary in order to meet the grading or plasticity requirements, or for satisfactory bonding of the material, it shall be uniformly blended with the crushed rock material at the crushing and screening plant prior to placing on the road, unless otherwise agreed. The material for such purposes shall be obtained from sources approved by the Authorized Officer and shall be free from stones, vegetative matter, and other deleterious materials.
- 1008a - Each layer of crushed rock material shall be thoroughly mixed on the roadbed by alternately blading, to full depth, until a uniform mixture has been obtained. The mixture shall then be spread to full width. When completed, the spreading shall produce a surface which is smooth, presents uniform shoulder lines, and conforms to the specified cross section.
- 1009 - The roadbed, as shaped and compacted under Sections 300 and 500 of these specifications, shall be approved by the Authorized Officer prior to placement of crushed rock materials. Notification for final inspection prior to rocking shall be 72 hours prior to that inspection and shall be 7 days prior to start of rocking operations.
- 1010 - Crushed rock materials shall be placed and processed on the approved roadbed in accordance with these specifications and conforming to the lines, grades, dimensions, and typical cross sections shown on the plans, and compacted in layers not to exceed 6 inches in depth. When more than one layer is required, each shall be shaped, processed, compacted, and approved by the Authorized officer before the succeeding layer is placed. Irregularities or depressions that develop during compaction of the top layer shall be corrected by loosening the material at these places and adding or removing crushed rock material until the surface is smooth and uniform.



AGGREGATE BASE COURSE - 1000  
CRUSHED ROCK MATERIAL

- 1010a - Crushed rock material used to repair or reinforce soft, muddy, frozen, yielding, or rutted roadbed shall not be construed as surfacing under this specification.
- 1012 - Each layer of crushed rock material for base shall be placed, processed, shaped, moistened or dried to uniform moisture content suitable for maximum compaction, and compacted to full width by compaction equipment conforming to the requirements of Subsection 103f and 103i. Minimum compaction shall be deemed adequate when the surface can withstand five passes of a truck, with H-20 loading without appreciable deformation.

AGGREGATE SURFACE COURSE - 1200  
CRUSHED ROCK MATERIAL

- 1201 - This work shall consist of furnishing, hauling, and placing one or more layers of crushed rock material on roadbeds and base courses approved for placing crushed rock material in accordance with these specifications and conforming to the dimensions and typical cross sections shown on the plans. Material not conforming to these specifications will be rejected and shall be removed from the road at the purchaser's expense.
- 1202a - Crushed rock materials used in this work may be obtained from commercial sources selected by the Purchaser at his option and expense, providing the rock materials furnished comply with the specifications.
- 1203 - When crushed rock material is produced from gravel, not less than 65 percent by weight of the particles retained on the No. 4 sieve will have 2 manufactured fractured faces. If necessary, to meet the above requirements or to eliminate an excess of filler, the gravel shall be screened before crushing.
- 1204 - Crushed rock material shall consist of hard durable rock fragments conforming to the following gradation requirements:

TABLE 1204

AGGREGATE SURFACE COURSE  
CRUSHED ROCK MATERIAL

Percentage by weight passing square mesh sieves  
 AASHTO T 11 & T 27

GRADATION

Sieve Designation	C	C-1	D	D-1	E	E-1
1-1/2-inch	100	100	-	-	-	-
1-inch	-	-	100	100	-	-
3/4-inch	50-90	60-90	-	70-98	100	100
1/2-inch	-	-	-	-	-	70-98
No. 4	25-50	30-55	30-60	36-60	40-75	44-70
No. 8	-	22-43	-	25-47	-	30-54
No. 30	-	11-27	-	12-31	-	15-34
No. 40	5-25	-	5-30	-	5-35	-
No. 200	2-15	3-15	3-15	3-15	2-15	3-15

AGGREGATE SURFACE COURSE - 1200  
CRUSHED ROCK MATERIAL

- 1204a - The Purchaser shall be required to take one sample for each 1,000 cubic yards of crushed rock material to be utilized using AASHTO sampling procedures. The Purchaser shall submit samples to a certified lab or perform testing for gradation requirements using AASHTO T 11 and AASHTO T 27 testing procedures. Prior to testing, each sample shall be split, making one half of the sample, with proper identification, available for testing by the Authorized Officer. Each sample and the results of Purchaser testing shall be made available to the Authorized Officer within 24 hours of sampling. The Purchaser shall provide test results for the first 500 cubic yards produced prior to commencing production crushing and hauling.
- 1205 - Crushed rock material shall not exceed 35 percent loss as determined by AASHTO T96.
- 1206 - Crushed rock material shall show a durability value of not less than 35 as determined by AASHTO T210.
- 1208 - If additional binder or filler material is necessary to meet the grading or plasticity requirements or for satisfactory bonding of the material, it shall be uniformly blended with the crushed rock material at the crushing and screening plant prior to placing on the road, unless otherwise agreed. The material for such purposes shall be obtained from sources approved by the Authorized Officer and shall be free from stones, vegetative matter, and other deleterious materials.
- 1208a - Each layer of crushed rock material shall be thoroughly mixed on the roadbed by alternately blading, to full depth, until a uniform mixture has been obtained. The mixture shall then be spread to full width. When completed, the spreading shall produce a surface which is smooth, presents uniform shoulder lines, and conforms to the specified cross section.
- 1209 - Shaping and compacting of roadbed and base course shall be completed and approved, prior to placing crushed rock material, in accordance to the requirements of Subsections 300 and 500 for placing on the roadbed and landings and Subsection 1000 for placing on the base course. Notification for final inspection prior to rocking shall be 7 days prior to the inspection and shall be 10 days prior to start of surfacing operations.

AGGREGATE SURFACE COURSE - 1200  
CRUSHED ROCK MATERIAL

- 1210 - Crushed rock material conforming to the requirements of these specifications shall be placed on the approved roadbed, landings, and base course in accordance with these specifications and conforming to the lines, grades, dimensions, and typical cross sections shown on the plans. Compacted layers shall not exceed 4 inches in depth. When more than one layer is required, each shall be shaped, processed, compacted, and approved by the Authorized Officer before the succeeding layer is placed. Irregularities or depressions that develop during compaction of the top layer shall be corrected by loosening the material at these places and then adding or removing crushed rock material until the surface is smooth and uniform.
- 1210a - Crushed rock material used to repair or reinforce soft, muddy, frozen, yielding, or rutted roadbed shall not be construed, as surfacing required by this specification.
- 1212 - Each layer of crushed rock material placed, processed, and shaped as specified shall be moistened or dried to a uniform moisture content suitable for maximum compaction and compacted to full width by compacting equipment conforming to the requirements of Subsection 103f. Minimum compaction shall be 1 hour of continuous compacting for each 6 stations, or fraction thereof.

EROSION CONTROL - 1700

- 1701 - This work shall consist of measures to control soil erosion or water pollution during the construction operation through the use of berms, dikes, dams, sediment basins, fiber mats, netting, gravel, mulches, grasses, slope drains and other erosion control devices or methods in accordance with these specifications and conforming to the lines, grades, dimensions and typical cross sections shown on the plans.
- 1704 - The erosion control provisions specified under this Subsection shall be coordinated with the Soil Stabilization requirements of section 1800.
- 1705 - The surface area of erodible earth material exposed at any one time by clearing and grubbing shall not exceed 4000 square feet after September 15, without prior approval by the Authorized Officer.
- 1706 - The surface area of erodible earth material exposed at one time by excavation, borrow, or fill within the right-of-way shall not exceed 4000 square feet after September 15, without prior approval by the Authorized Officer.



SOIL STABILIZATION – 1800

If seed is not available that meets the factors in the above table, the project area would be sown with seed approved by the resource area botanist. Prior to applying seed, the contractor will supply the BLM with the seed label showing testing results.

- 1806a - Additional soil stabilization work consisting of seeding and mulching, may be required at the option of the Authorized Officer. Providing the additional stabilization is not due to Purchaser negligence as specified in Sec. 12 of the contract, a reduction in the total purchased price shall be made to offset the cost of furnishing and applying such additional stabilization material. Cost shall be based upon the unit price set forth in the current BLM Timber Appraisal Production Cost Schedule.
- 1808 - Mulch materials conforming to the requirements of Subsections 1808a shall be furnished by the Purchaser and applied in accordance with Subsection 1812.
- 1808a - Straw mulch shall be certified weed free from commercial grain fields and native grass fields. Straw mulch shall be from oats, wheat, rye, or other approved grain crops which are free from mold, or other objectionable materials. Straw mulch shall be in an air-dry condition and suitable for placement.
- 1809 - Mulch material shall be delivered to the work area in a dry state. Material found to be wet will not be accepted. Material to be used in the mulching operation may be stockpiled along the road designated for treatment provided that it is maintained in a dry state and has the approval of the Authorized Officer.
- 1810 - Bulk mulching material required under these specifications shall be delivered to the work area bound either by twine, string or hemp rope. Wire binding will not be permitted.
- 1814 - The Purchaser may reduce the application rate on partially covered slopes and refrain from application on areas already well stocked with grass, or on rock surfaces, as determined by the Authorized Officer.
- 1815 - The seed and mulch materials shall be placed by the dry method in accordance with the requirements set forth in Subsection 1815b.

SOIL STABILIZATION - 1800

- 1815b - Dry Method - Blowers, mechanical seeders, seed drills, landscape seeders, cultipaker seeders, fertilizer spreaders or other approved mechanical seeding equipment may be used when seed and fertilizer are to be applied in dry form.
- 1818 - At the beginning of each day's operation, a measured area will be seeded and mulched to assure uniform application.
- 1819 - The maximum distance to be seeded and mulched from the road centerline shall be 100 feet for the cut slopes and 150 feet for the fill slopes.
- 1820 - The Purchaser shall notify the Authorized Officer at least 3 days in advance of date he intends to commence the specified soil stabilization work.
- 1822 - Mulch that collects at the end of culverts or accumulates to excessive depths on the slopes shall be evenly spread by hand methods, as directed by the Authorized Officer.
- 1823 - No materials shall be applied when wind velocities would prevent a uniform application of the mix or slurry or when winds would drift the mix or slurry spray outside of the designated treatment area.
- 1826 - Twine, rope, sacks, and other debris resulting from the soil-stabilization operation shall be picked up and disposed of to the satisfaction of the Authorized Officer.

ROADSIDE BRUSHING - 2100

- 2101 - This work shall consist of the removal of vegetation from the road prism - variable distance, and inside curves in accordance with these specifications and conforming to the lines, grades, dimensions, and typical cross sections shown on the Roadside Brushing Detail Sheet of this exhibit, at designated locations as shown in the plans.
- 2102 - Roadside brushing may be performed mechanically with self powered, self-propelled equipment or manually with hand tools, including chain saws.
- 2103 - Vegetation, cut manually or mechanically, less than 6 inches in diameter at D.B.H.O.B., shall be cut to a maximum height of 3 inches above the ground surface or above obstructions such as rocks or stumps, on cut and fill slopes. All limbs below the 3 inch area will be severed from the trunk.

ROADSIDE BRUSHING - 2100

- 2103a - Vegetation shall be cut and removed from the road bed between the outside shoulders and the ditch centerline and such vegetation shall be cut to a maximum height of 1 inch above the ground and running surface. Limbs below the 1 inch area will be severed from the trunk. Sharp pointed ends will not be permitted. Cuts shall be parallel to the ground line or running surface.
- 2104 - Trees in excess of 6 inches in diameter at D.B.H.O.B. shall be limbed, so that no limbs extend into the treated area or over the roadbed to a height of 14 feet above the running surface of the roadway on cut and fill slopes, within the road prism-variable distance. Limbs shall be cut to within 1 inch of the trunk to produce a smooth vertical face. Removal of trees larger than 6 inches in diameter for sight distance or safety may be directed by the Authorized Officer.
- 2105 - Vegetation that is outside of the road prism-variable distance that protrudes into the road prism and within 14 feet in elevation above the running surface shall be cut, to within 1 inch of the trunk to produce a smooth vertical face.
- 2106 - Vegetative growth capable of growing 1 foot in height or higher shall be cut, within the road prism-variable distance or as directed by the Authorized Officer.
- 2107 - Inside curves shall be brushed out for a sight distance of 200 feet chord distance or a middle ordinate distance of 25 feet whichever is achieved first. Overhanging limbs and vegetation in excess of 1 foot in height shall be cut within these areas.
- 2108 - Self-propelled equipment shall not be permitted on cut and fill slopes or in ditches.
- 2109 - Debris resulting from this operation shall be scattered downslope from the roadway. Debris shall not be allowed to accumulate in concentrations. Debris in excess of 1 foot in length and 2 inches in diameter shall not be allowed to remain on cut slopes, ditches, roadways or water courses, or as directed by the Authorized Officer.



ROADSIDE BRUSHING - 2100

2112 - Roadside brushing shall be accomplished as shown on the plans and as listed below:

Road No.	From Sta./M.P.	To Sta./M.P.
8-8-11.1	0.08	0.32
8-8-11.2	0.00	0.21
8-8-11.3	0.00	0.13
8-8-11.4	0.00	0.45
8-8-11.5	0.00	0.09
8-8-11.6	0.00	0.08
8-8-11.7	0.00	0.23
8-8-11.8	0.00	0.31
8-8-12	1.23	2.95
P5	0+00	3+86
P6	0+00	5+28
P7	0+00	1+65

2115 - Mechanical brush cutters shall not be operated when there are people and occupied vehicles within 400 feet of the immediate operating area.

2116 - Traffic warning signs shall be required at each end of the work area. Signs shall meet the requirements of the Manual on Uniform Traffic Control Devices.

ROAD DECOMMISSIONING - 2700

2701 - This work consists of decommissioning the following roads:

Road Number	Length
P5	0.07
P6	0.10
P7	0.03

This work is not required for road acceptance under Section 18 of this contract.

ROAD DECOMMISSIONING - 2700

- 2702 - Decommissioning shall consist of removing cross drains and removing crossing by excavating fill material and placing in locations to form partially recontoured roadway sections. Work includes installing water bars, drain dips and placement of slash and placement of soil stabilization material. This work is not required under Section 18 of this Contract and in accordance with Exhibit D section 3500.
- 2703 - Where windrows, berms, or vegetation exist along the outside shoulder of the decommissioned roadbed, they shall be removed to promote drainage. Outlet channels will be constructed at as frequent of locations as possible where trees interfere with drainage.
- 2704 - Water bars shall be installed on the road listed in Subsection 2601, at the following intervals:

	Spacing Distance
0 - 5%	400 feet
6 - 12%	300 feet
13% and greater	200 feet

at locations approved by the Authorized Officer, and in accordance with these specifications and conforming to the lines, grades, dimensions, and typical cross sections shown on the plans, skipping locations that are at high points.

- 2706 - Soil stabilization work consisting of seeding and mulching shall be performed as specified under Section 1800, in areas left exposed as a result of logging, final road maintenance, or decommissioning operations.

ROAD RENOVATION WORKLIST

MP - Work to be Accomplished

Road renovation as required under Exhibit C of this contract shall include, but is not limited to the following worklist. All existing roads shall be brushed, shall be graded and compacted to their full width, shall have the ditches cleared of any blockages, and shall have existing culverts and catch basins cleaned at locations that are not listed in Section 400 for replacement. Any soils left exposed after renovation or new construction activities shall be seeded and mulched. Roadside tree removal shall be accomplished prior to culvert installations and aggregate placement. Roadside trees shall not be felled onto existing roads. Processing shall not be accomplished on top of existing aggregate surfaces. Logging slash and log decks shall not be placed in ditches, in catch basins, or on top of outlets of culverts.

Road No. 8-8-11.1

MP

- 0.00 - No maintenance or construction actions will begin until BLM property line.
- 0.08 Begin renovation work as described in Sections 150, 500, and this worklist. Begin brushing as described in Section 2100. Begin placement, grading, and compaction 6" lift of 1.5" minus.
- 0.32 - End of renovation at private property line. End of 6" lift of 1.5" minus.

Road No. 8-8-11.2

MP

- 0.00 - Begin renovation work as described in Sections 150, 500, and this worklist. Begin brushing as described in Section 2100. Begin placement, grading, and compaction 6" lift of 1.5" minus.
- 0.13 - End of renovation at junction with 8-8-11.3 road to left.

Road No. 8-8-11.3

MP

- 0.00 - Begin renovation work as described in Sections 150, 500, and this worklist. Begin brushing as described in Section 2100. Begin placement, grading, and compaction 6" lift of 1.5" minus.
- 0.13 End of renovation.

Road No. 8-8-11.4

MP

- 0.00 - Begin renovation work as described in Sections 150, 500, and this worklist. Begin brushing as described in Section 2100. Begin placement, grading, and compaction 6" lift of 1.5" minus.
- 0.45 End renovation.

Road No. 8-8-11.5

MP

- 0.00 - Begin renovation work as described in Sections 150, 500, and this worklist. Begin brushing as described in Section 2100. Begin placement, grading, and compaction 3" lift of 1.5" minus.
- 0.07 Place, grade, and compact 100' x 50' x 8" lift of 3" minus to construct ground based landing pad.
- 0.09 - End of renovation.

Road No. 8-8-11.6

MP

- 0.00 - Begin renovation work as described in Sections 150, 500, and this worklist. Begin brushing as described in Section 2100. Begin placement, grading, and compaction 3" lift of 1.5" minus.
- 0.06 Place, grade, and compact 100' x 50' x 8" lift of 3" minus to construct ground based landing pad.
- 0.08 - End of renovation.

Road No. 8-8-11.7

MP

- 0.00 - Begin renovation work as described in Sections 150, 500, and this worklist. Begin brushing as described in Section 2100. Begin placement, grading, and compaction 6" lift of 1.5" minus.
- 0.11 Place, grade, and compact 100' x 50' x 8" lift of 3" minus to construct cable landing pad.
- 0.15 Place, grade, and compact 100' x 50' x 8" lift of 3" minus to construct cable landing pad.
- 0.21 Place, grade, and compact 100' x 50' x 8" lift of 3" minus to construct cable landing pad.
- 0.23 - End of renovation.

Road No. 8-8-11.8

MP

- 0.00 - Begin renovation work as described in Sections 150, 500, and this worklist. Begin brushing as described in Section 2100. Begin placement, grading, and compaction 6" lift of 1.5" minus.
- 0.02 Replace existing 12"x28' metal cross drain with 24"x30' corrugated plastic pipe.
- 0.31 - End of renovation.

Road No. 8-8-12

MP

- 0.00 - Begin road at junction with Black Rock Mainline. No maintenance or construction actions will begin until BLM property line.
- 1.29 Begin renovation work as described in Sections 150, 500, and this worklist. Begin brushing as described in Section 2100. Begin placement, grading, and compaction 6" lift of 1.5" minus.
- 1.30 Replace existing 18"x30' cross drain with 24"x30' corrugated plastic pipe.
- 2.04 End 6" lift of 1.5" minus at private property line.
- 2.38 Add downspout to existing 24"x40' aluminized pipe.
- 2.61 Replace 24"x24' cross drain with 24"x30' corrugated plastic pipe and 15' downpipe..
- 2.75 Replace 24"x40' corrugated metal pipe on small intermittent stream with 24"x45' aluminized pipe with 15' downspout. Place 10 cubic yards of riprap in existing pool as a splash pad.
- 2.83 Add 24"x40' corrugated plastic pipe for ditch line relief before stream crossing.
- 2.95 - End of renovation at junction with R3 road to left.

Road No. P5

Sta.

- 0+00 Begin new construction work as described in Sections 150, 200, 300, and this worklist. Soil stabilization and erosion control measures will be required as necessary and as described in Sections 1700 and 1800. Begin placement, grading, and compaction 6" lift of 1.5" minus.
- 3+51 Begin taper to landing.
- 3+76 Place, grade, and compact 100' x 50' x 8" lift of 3" minus to construct cable landing pad.
- 3+86 - End of landing and new construction.

Road No. P6

Sta.

- 0+00      Begin new construction work as described in Sections 150, 200, 300, and this worklist. Soil stabilization and erosion control measures will be required as necessary and as described in Sections 1700 and 1800. Begin placement, grading, and compaction 6" lift of 1.5" minus.
- 1+65      Install 24"x40' corrugated plastic cross drain.
- 4+10      Begin taper to landing.
- 4+35      Place, grade, and compact 100' x 50' x 8" lift of 3" minus to construct cable landing pad.
- 5+28      End of landing and new construction.

Road No. P7

Sta.

- 0+00      Begin improvement work as described in Sections 150, 200, 300, and this worklist. Soil stabilization and erosion control measures will be required as necessary and as described in Sections 1700 and 1800. Begin placement, grading, and compaction 6" lift of 1.5" minus.
- 0+35      Begin taper to landing.
- 0+50      Place, grade, and compact 100' x 50' x 8" lift of 3" minus to construct cable landing pad.
- 1+58      -      End of landing and improvement.

NORTHWEST OREGON DISTRICT

**ROADSIDE BRUSHING  
DETAIL SHEET**

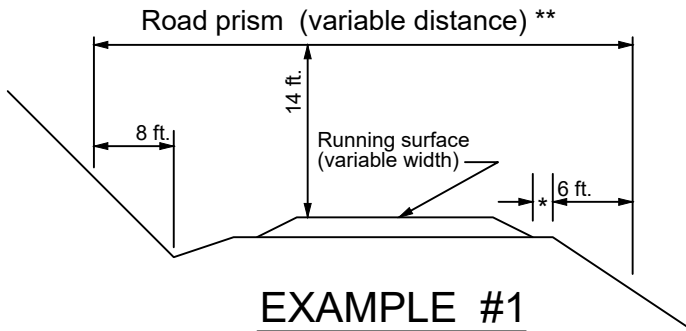

**EXAMPLE #1**

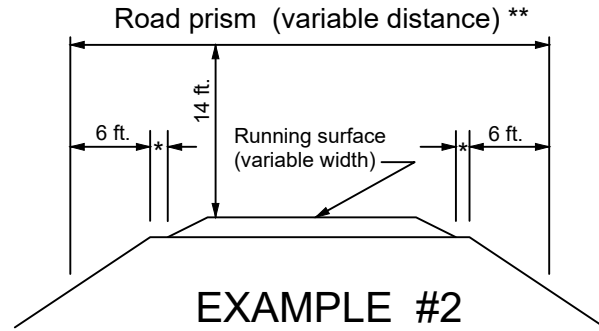

**EXAMPLE #2**

(NO SCALE)

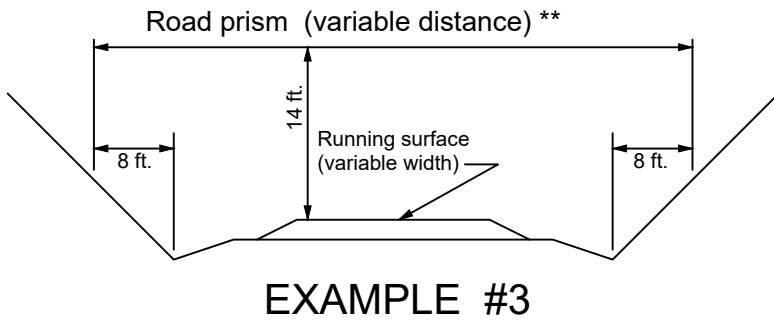

**EXAMPLE #3**

- \* Variable distance between running surface and start of fill slope.
- \*\* All areas within the variable distance shall be free of all vegetation capable of growing one (1) foot in height or higher and all overhanging limbs and branches 14 feet in elevation above the running surface.

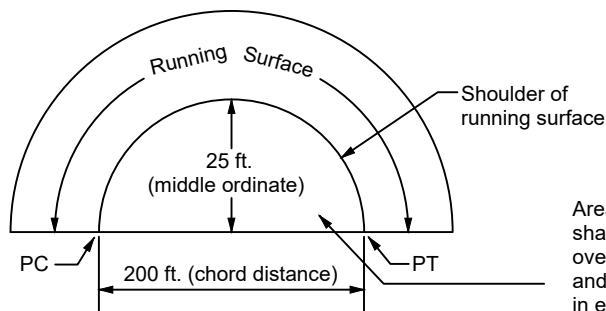

**SIGHT DISTANCE DIAGRAM**

Area to be cut:  
shall be free of  
overhanging limbs  
and all vegetation  
in excess of 1 foot  
in height.

**NOTE:**

Prior to beginning roadside brushing the purchaser shall establish a control section in a location determined by the Authorized Officer. This section will be used to physically and visually establish acceptable cutting and cleanup standards to be used for the remaining roadside brushing.



**U.S. DEPARTMENT OF THE INTERIOR**  
**Bureau of Land Management**  
**Northwest Oregon District**

EXHIBIT C  
HUMBARD'S  
ORN02-TS-2024.0203  
SHEET 39 OF 43

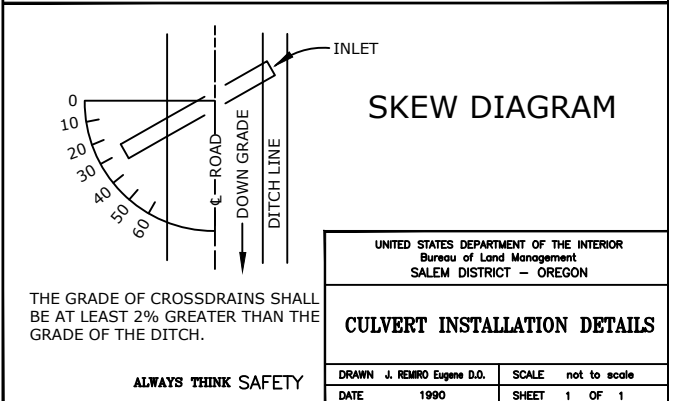
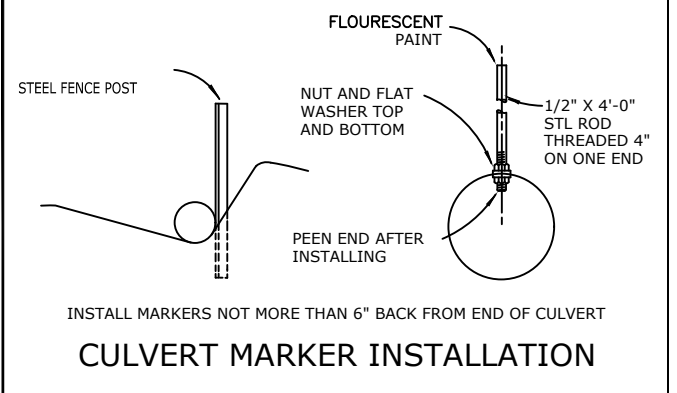
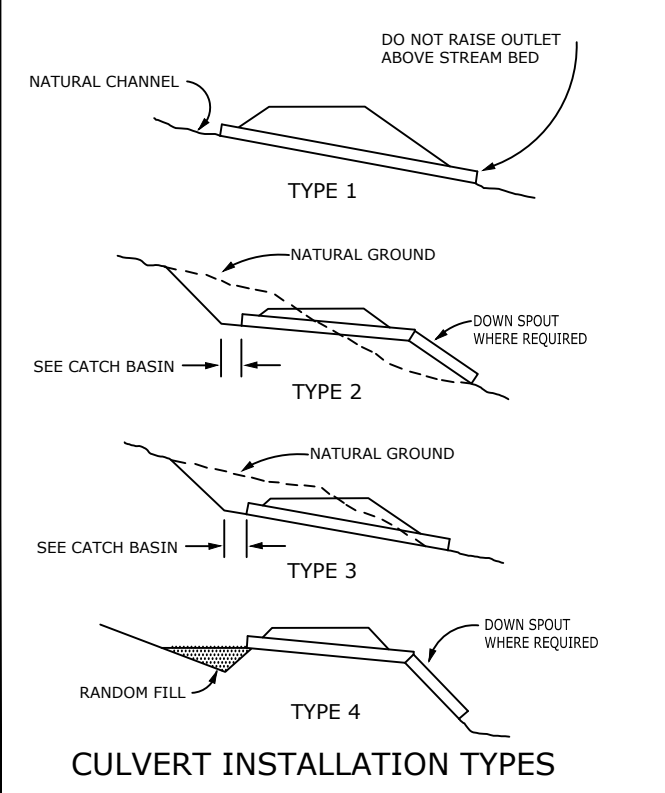
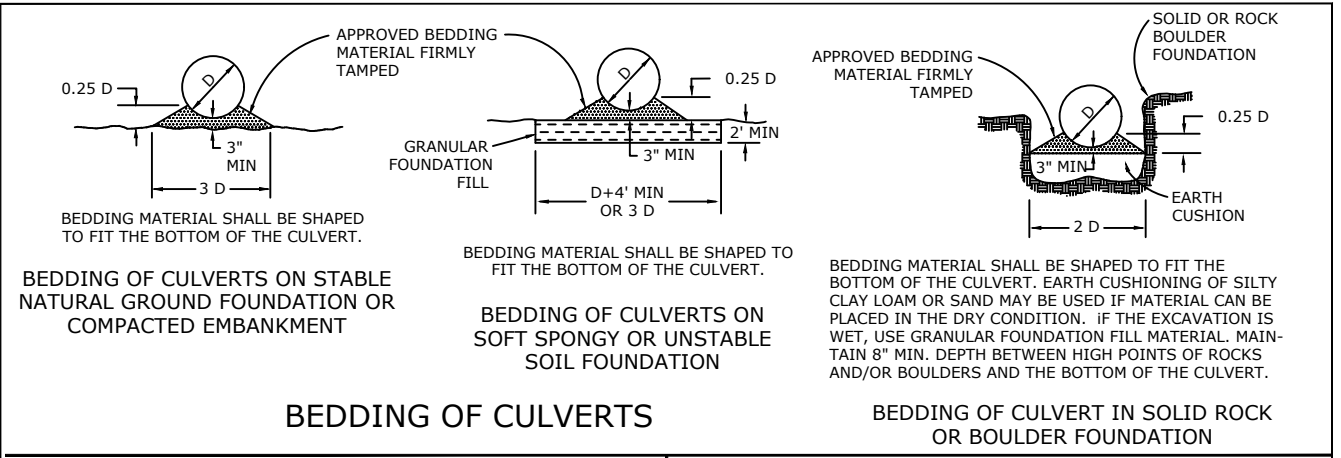
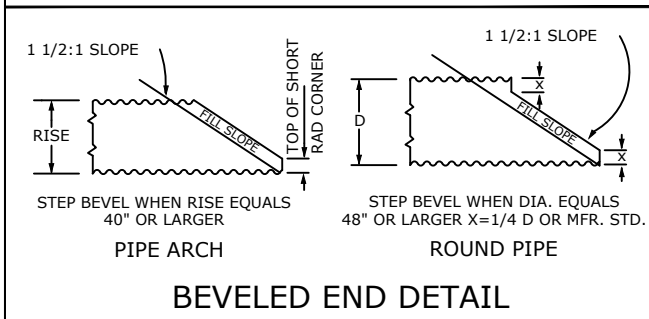
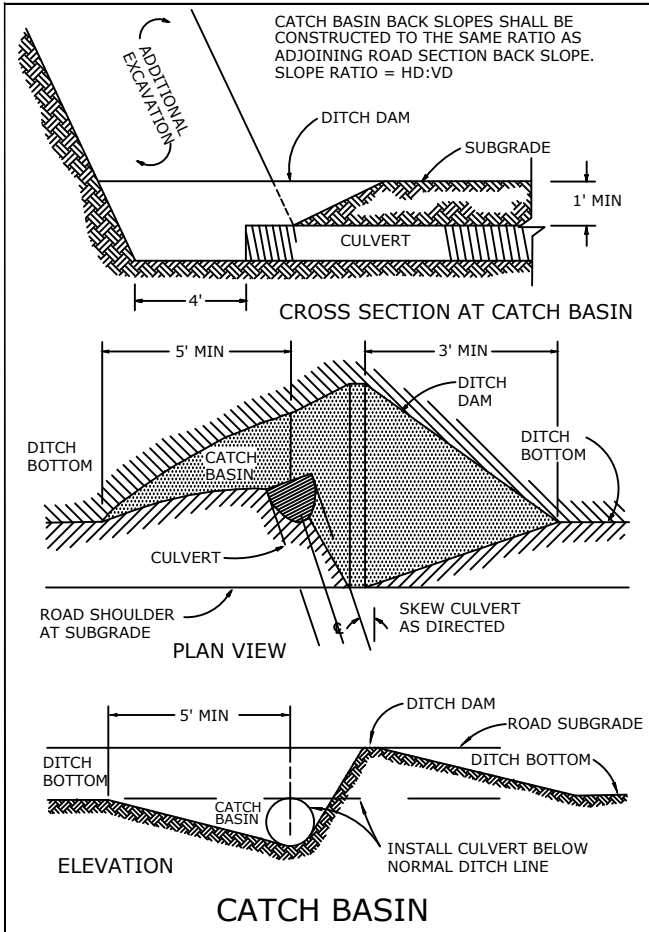

**U.S. DEPARTMENT OF THE INTERIOR**  
**Bureau of Land Management**  
**Northwest Oregon District**

EXHIBIT C  
HUMBARD'S  
ORN02-TS-2024.0203  
SHEET 40 OF 43

NOTE:  
DESIGN VARIATIONS IN FASTENERS,  
(STRAPs, BARS & WELDS) WHICH  
PROVIDE A TENSILE STRENGTH OF  
7500 LBS. ARE PERMISSIBLE.

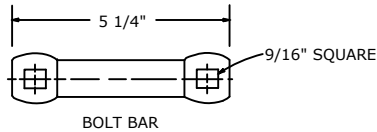
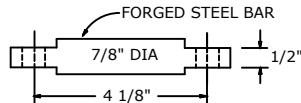
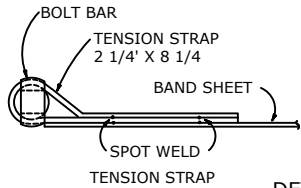

TENSION STRAP  
AND BOLT BAR.  
SEE DETAIL A

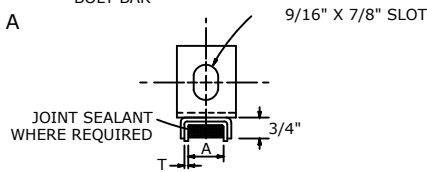
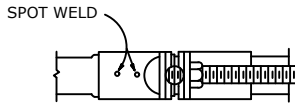
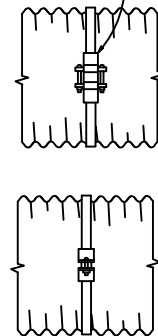

DIMENSIONS IN INCHES

T	A	PIPE WALL THICKNESS
.079	3/4	.109 OR LIGHTER
.109	1	.138 OR HEAVIER

SECTION A-A

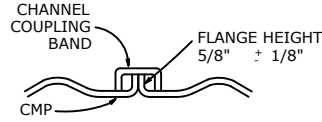
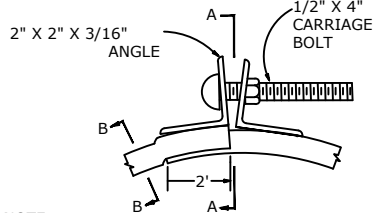

SECTION B-B

**CHANNEL  
BAND  
COUPLER**

NOTE:  
AS AN ALTERNATE TO SWEDGE, AN  
OVERSIZE BRIDGE CLIP MAY BE USED.

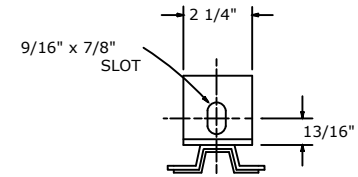

SECTION C-C

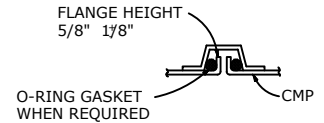
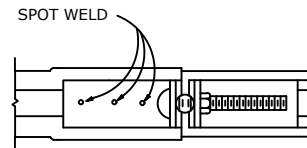
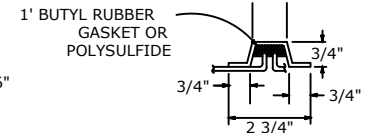

SECTION D-D

SHOWN WITH ALTERNATE TYPES  
OF JOINT SEALERS

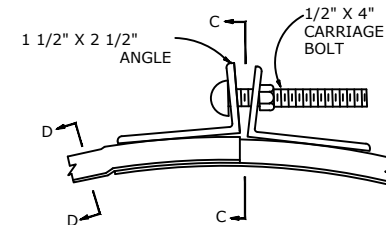

**FLANGED END COUPLER**

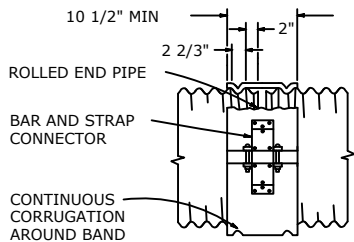
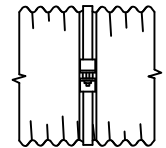

STANDARD CONSTRUCTION IS 1 PIECE 12"  
THRU 48" AND 2 PIECE 54" AND ABOVE

THE HUGGER COUPLER BAND OR AN APPROVED EQUIVALENT  
COUPLER BAND SHALL BE MADE OF THE SAME MATERIAL AND  
FINISH AS THE PIPES JOINED. THE COUPLER BANDS SHALL  
HAVE A MINIMUM WIDTH OF 10 1/2 INCHES AND MAY BE TWO  
NUMERICAL THICKNESSES LIGHTER THAN THE GAGE OR  
THICKNESS DESIGNATED FOR THE CONDUIT JOINED. THE BAND  
SHALL BE DESIGNED TO BE DRAWN TOGETHER WITH TWO  
1/2 INCH BOLTS THROUGH USE OF A BAR AND STRAP SUITABLY  
WELDED TO THE BAND. THE BAND SHALL ENGAGE AND MESH  
WITH THE SECOND ANNULER CORRUGATION INWARD FROM  
THE END OF EACH OF THE CONDUIT SECTIONS JOINED.

WHEN DESIGNATED ON THE PLANS OR ON THE SPECIAL  
PROVISIONS, GASKETS SHALL BE INSTALLED WHEN THE  
"HUGGER" TYPE, OR AN APPROVED EQUIVALENT COUPLER  
BAND IS INSTALLED ON SPILLWAY, OVERSIDE OR DOWN DRAINS.

**"HUGGER" COUPLER BANDS**

**STANDARD COUPLER BANDS**

CULVERT SIZE INCHES	CORRUGATED								FLAT-DIMPLED			
	STD. ANNULAR		HELICAL		3" X 1"		6" X 1"		WIDTH	NO. OF ROWS OF DIMPLES	NO. OF BOLTS	
	WIDTH	NO. OF BOLTS	WIDTH	NO. OF BOLTS	WIDTH	NO. OF BOLTS	WIDTH	NO. OF BOLTS			A	B
UNDER 18	7	2	7	2					10 1/2	2	2	2
18 TO 54	12	3	12	3	14	3	18	3	10 1/2	2	3	2
OVER 54	24	5	24	5	24	5	24	4	16 1/2	4	5	4

DATA IN THIS BLOCK DOES NOT APPLY TO PERFORATED PIPE UNDERDRAIN.  
FOR BANDS WITH "PUNCH-OUT" TYPE CONNECTIONS, 2 BOLTS ARE  
PERMISSIBLE FOR EACH LAP. BANDS SHALL LAP 1/2 WIDTH ONTO EACH  
SECTION OF PIPE AND MUST FULLY ENCLOSE THE JOINT FORMING A  
NEARLY WATERTIGHT CONNECTION.

- Ⓐ BANDS WITH ANGLES
- Ⓑ BANDS WITH TENSION TYPE CONNECTIONS

ALWAYS THINK S-FETY

UNITED STATES DEPARTMENT OF THE INTERIOR Bureau of Land Management S-LEM DISTRICT - OREGON	
<b>CULVERT BAND DETAILS</b>	
DR-WN J. REMIRO Eugene D.O.	SC-LE not to scale
D-TE 1990	SHEET 1 OF 1

**U.S. DEPARTMENT OF THE INTERIOR**  
**Bureau of Land Management**  
**Northwest Oregon District**

EXHIBIT C  
 HUMBARD'S  
 ORN02-TS-2024.0203  
 SHEET 41 OF 43

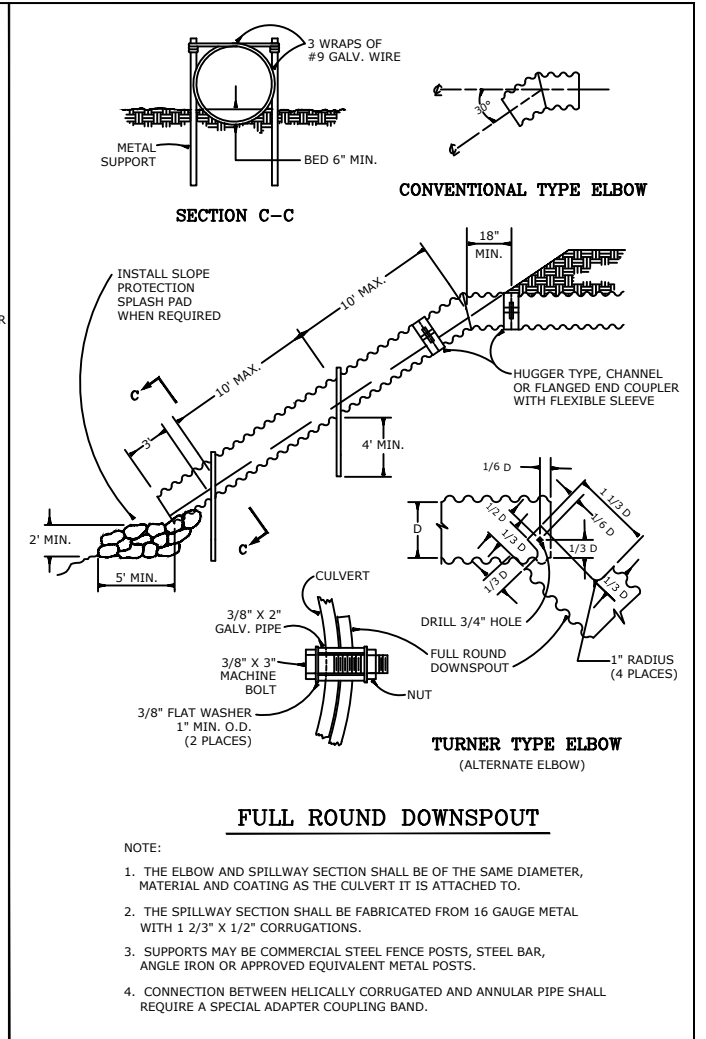
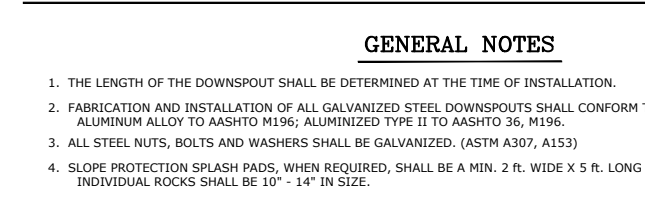
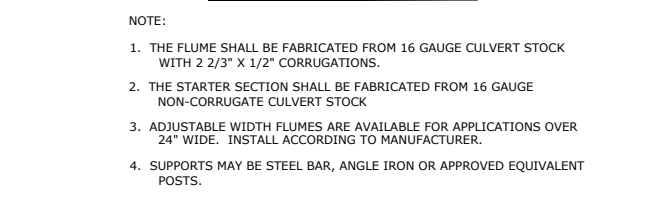
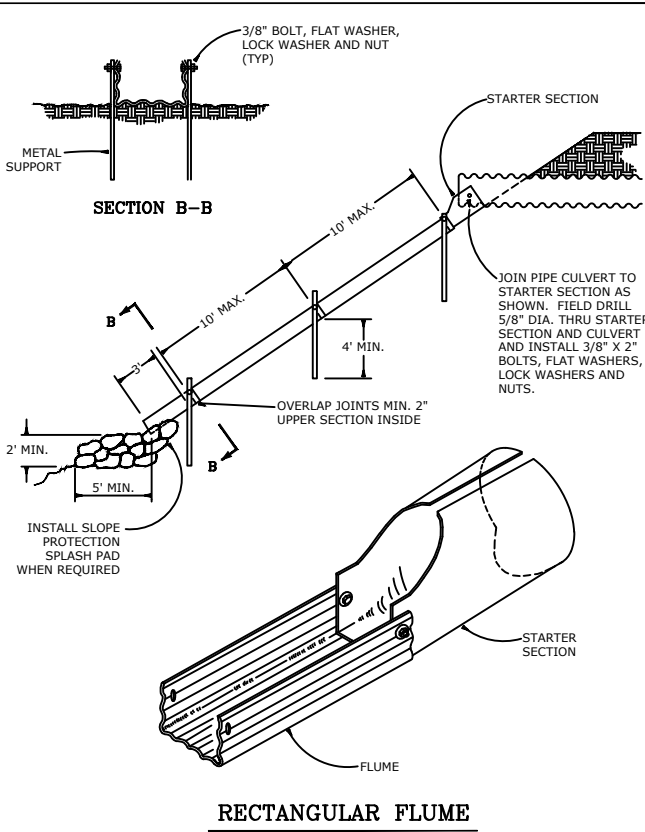
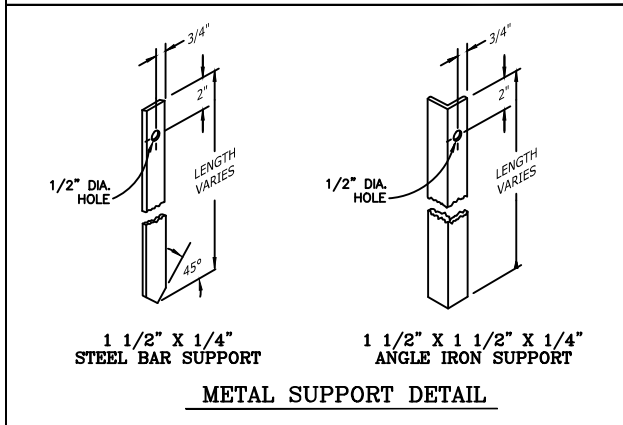
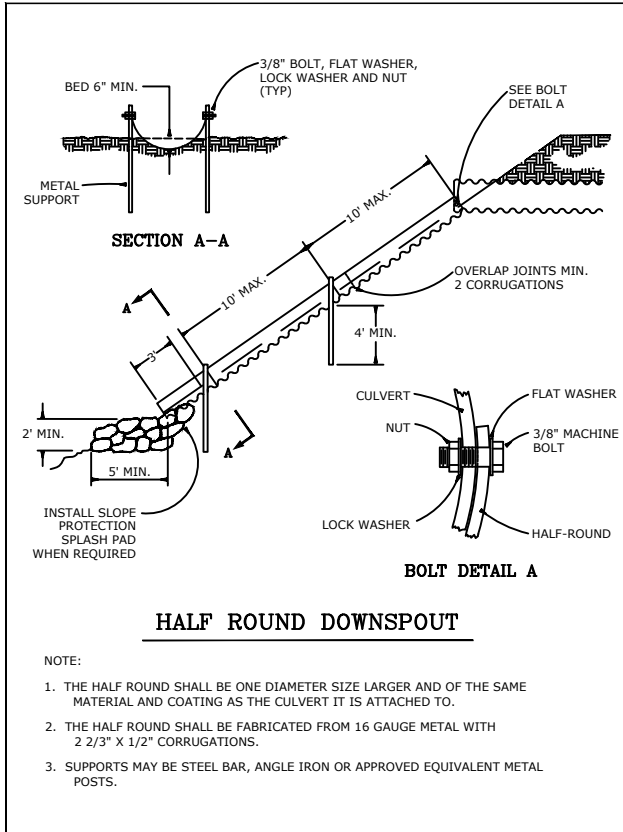

ALWAYS THINK SAFETY

UNITED STATES DEPARTMENT OF THE INTERIOR Bureau of Land Management SALEM DISTRICT - OREGON	
<b>DOWNSPOUT INSTALLATION DETAILS</b>	
DRAWN J. REMIRO Eugene D.O.	SCALE not to scale
DATE 1990	SHEET 1 OF 1

# U.S. DEPARTMENT OF THE INTERIOR

## Bureau of Land Management

### Northwest Oregon District

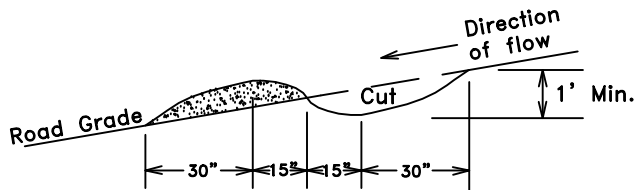

1. Waterbars shall be constructed as shown.
2. Exact locations will be flagged by the Authorized Officer prior to construction.
3. All waterbars shall be skewed 30 degrees.
4. Waterbars shall extend from the cut bank to the fill slope and be readily crossed by passenger type vehicles.
5. See itemized Project List for quantities and locations.

Typical Waterbar Details  
(Not to scale)

Typical Culvert Removal Details  
(Not to Scale)

Typical Debris Barricade Details  
(Debris & Earth berm)  
(Not to Scale)

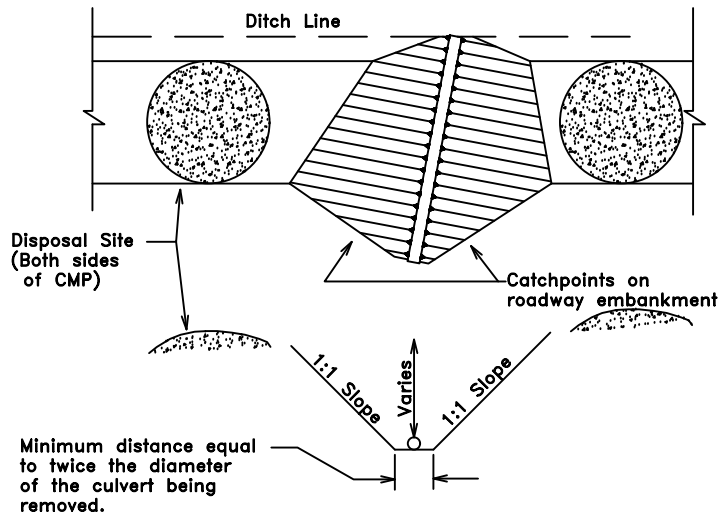

1. Culverts shall be removed as shown
2. Removed culverts shall be disposed of as directed by the Authorized Officer
3. The exposed areas shall be seeded in accordance with Section 1800, Exhibit C
4. Excavated material shall be stockpiled as shown

1. Roads shall be blocked as shown using available debris
2. All barricade material shall be stock piled in a large configuration of stumps, logs, large rocks, woody material and earth. Earth will be used to aid debris from being cut, stolen or moved from site.
3. Barricade locations will be flagged by the Authorized Officer prior to construction
4. The barricade shall span the entire width of the roadway and shall sufficiently block all vehicular access to the road

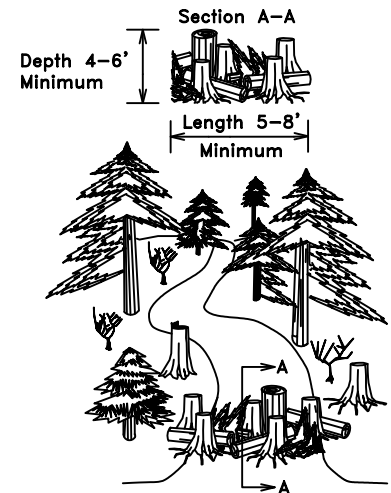



UNITED STATES DEPARTMENT OF THE INTERIOR  
 Bureau of Land Management  
**Road Plan Map**  
 T. 08 S. - R. 08 W.M., Section 11

Humbard's  
 ORN02-TS-2024.0203  
 Sheet 43 of 43  
**EXHIBIT C**

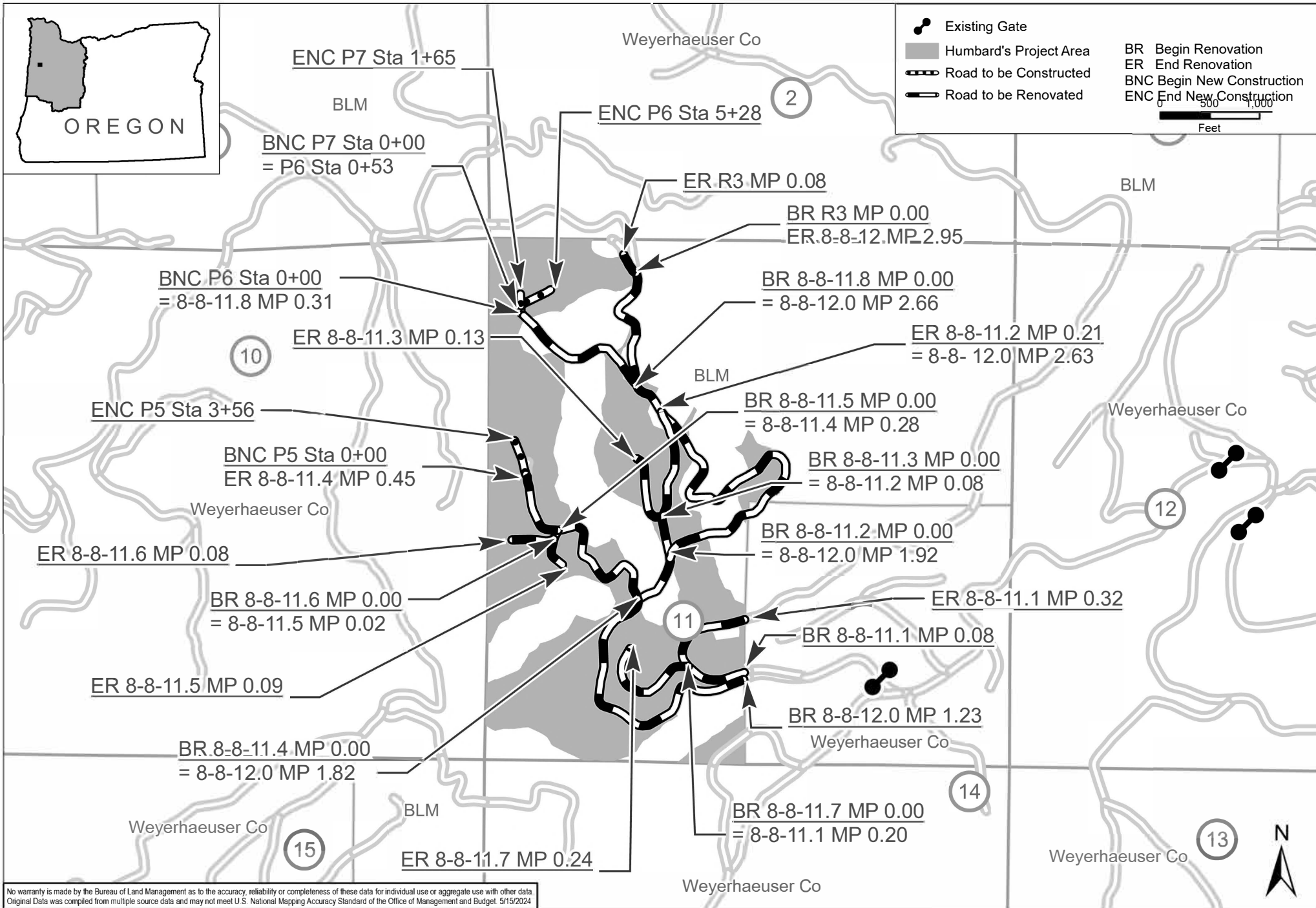

No warranty is made by the Bureau of Land Management as to the accuracy, reliability or completeness of these data for individual use or aggregate use with other data. Original Data was compiled from multiple source data and may not meet U.S. National Mapping Accuracy Standard of the Office of Management and Budget. 5/15/2024

**HUMBARO'S TS  
ORN02-TS-2024.0203  
APPENDIX C1**

**P5**



**Plan View**

Legend	
	Plan L-line Location
	Plan P-line Location
	Plan Road Edges
	Plan Clearing Limits
	Plan Cross Section Lines
	Profile Topography
	Profile Finished Grade

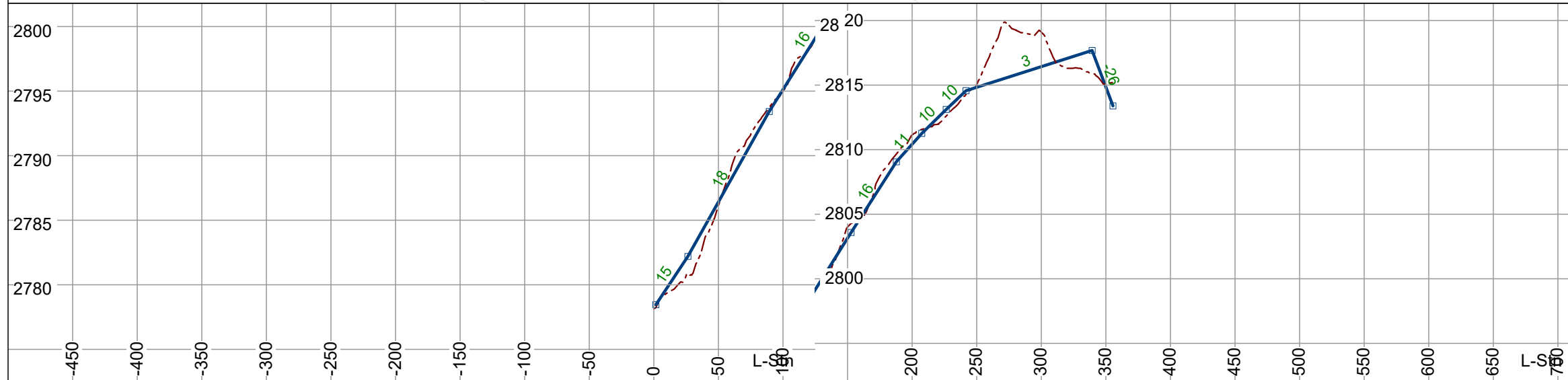

**Profile View**

Template Assignments			
ID	L-Stn From	L-Stn To	Description
DF	..	215.0	DEFAULT TEMP
TP	215.0	240.0	Taper Template
SMLD	240.0	..	60 Foot Wide La

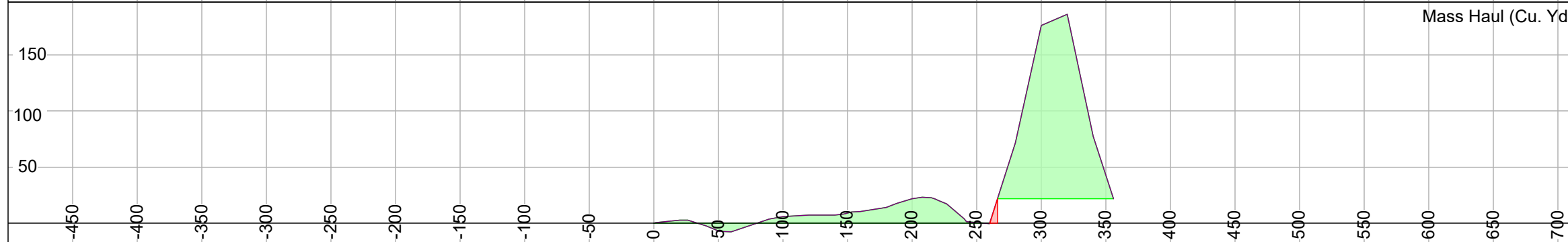

**Mass Haul**

**HUMBARO'S TS  
ORN02-TS-2024.0203  
APPENDIX C1**

**P6**

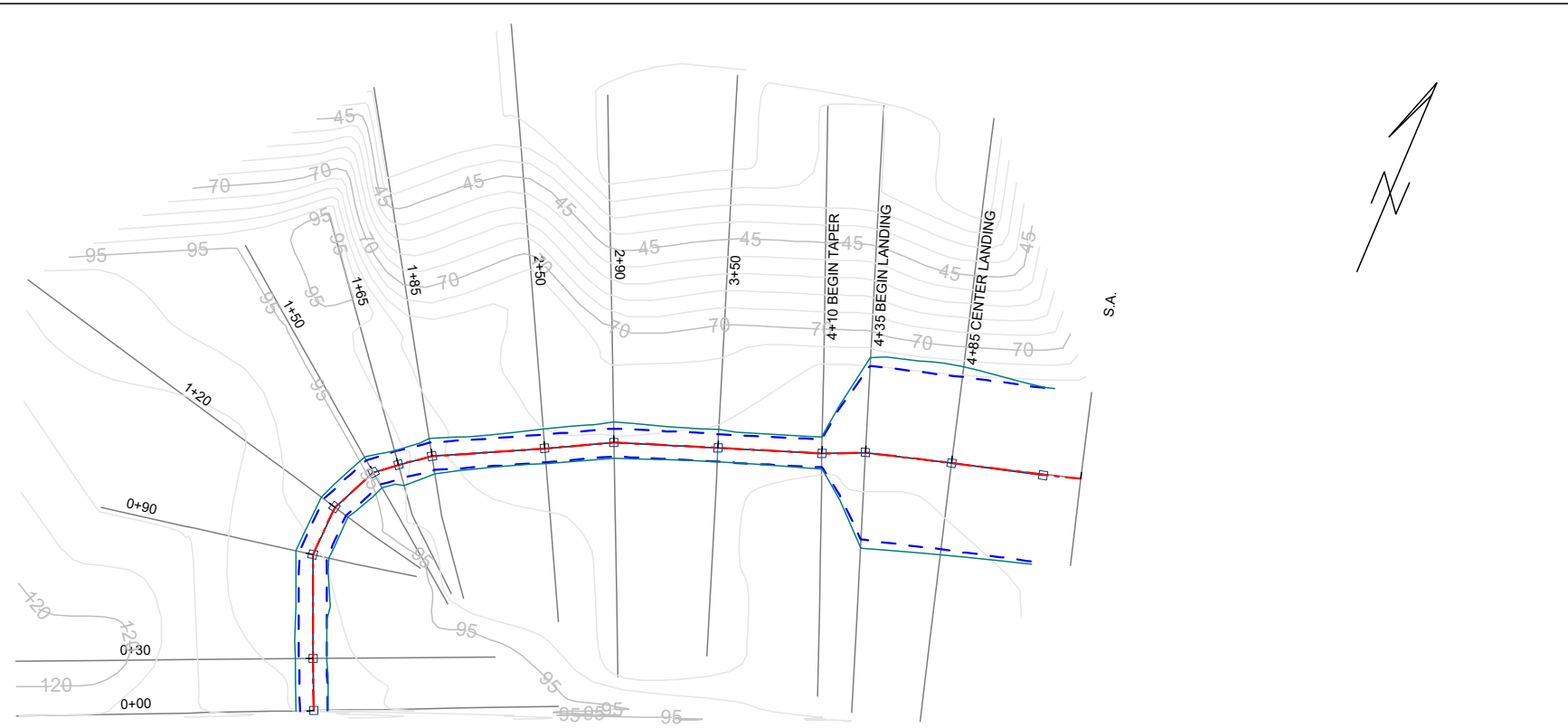

**Scale: 1" = 100'**

**Plan View**

**Legend**

	Plan L-line Location
	Plan P-line Location
	Plan Road Edges
	Plan Clearing Limits
	Plan Cross Section Lines
	Profile Topography
	Profile Finished Grade

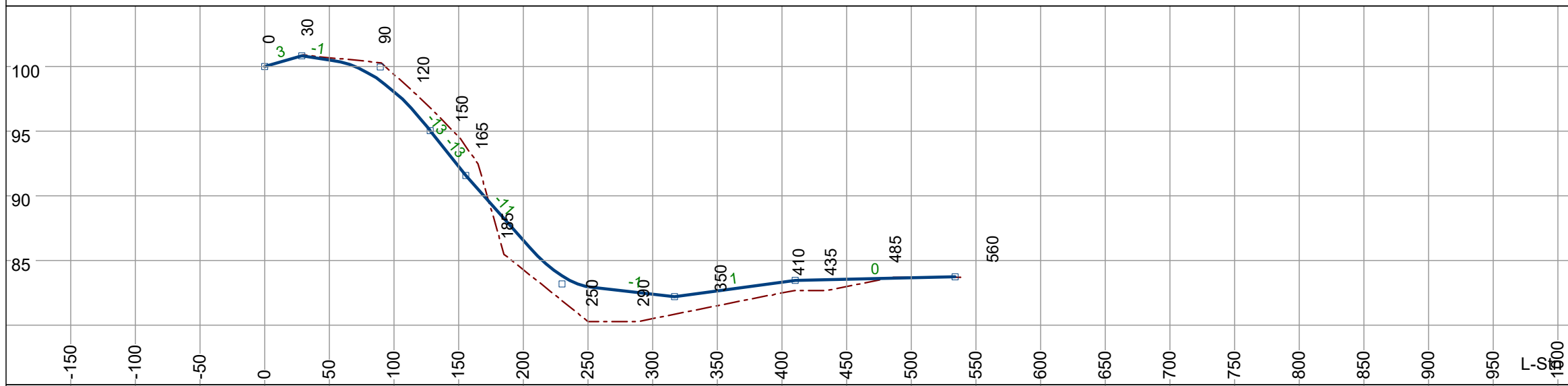

**Profile View**

**Template Assignments**

ID	P-Stn From	P-Stn To	Description
DF	..	410.0	DEFAULT TEMP
TP	410.0	435.0	Taper Template
LNDG	435.0	..	Landing

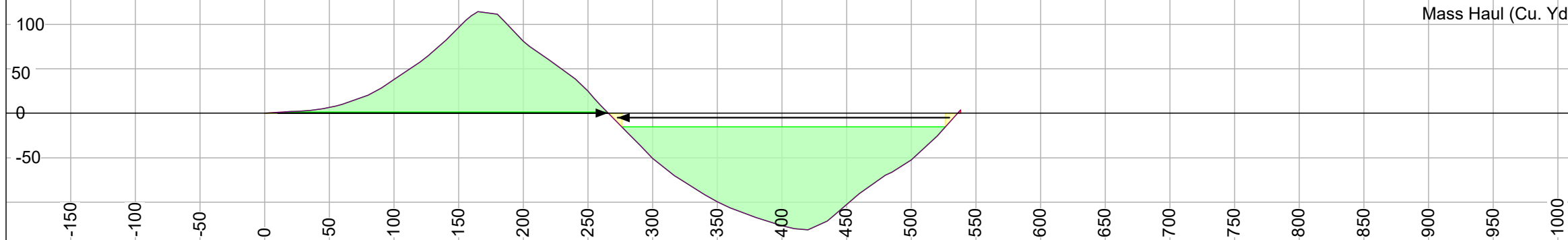

**Mass Haul**

**HUMBAR'S TS  
ORN02-TS-2024.0203  
APPENDIX C1**

**P7**

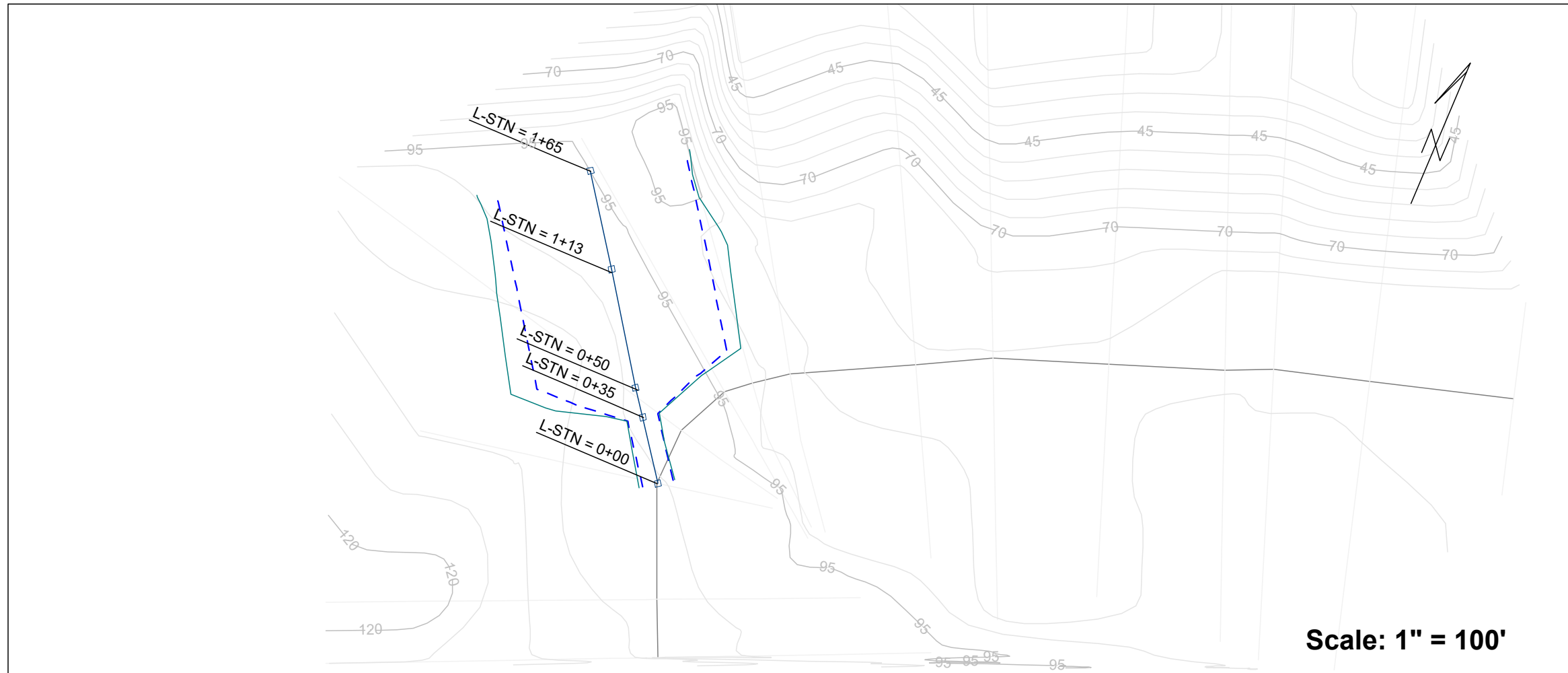

**Plan View**

Legend	
	Plan L-line Location
	Plan P-line Location
	Plan Road Edges
	Plan Clearing Limits
	Plan Cross Section Lines
	Profile Topography
	Profile Finished Grade

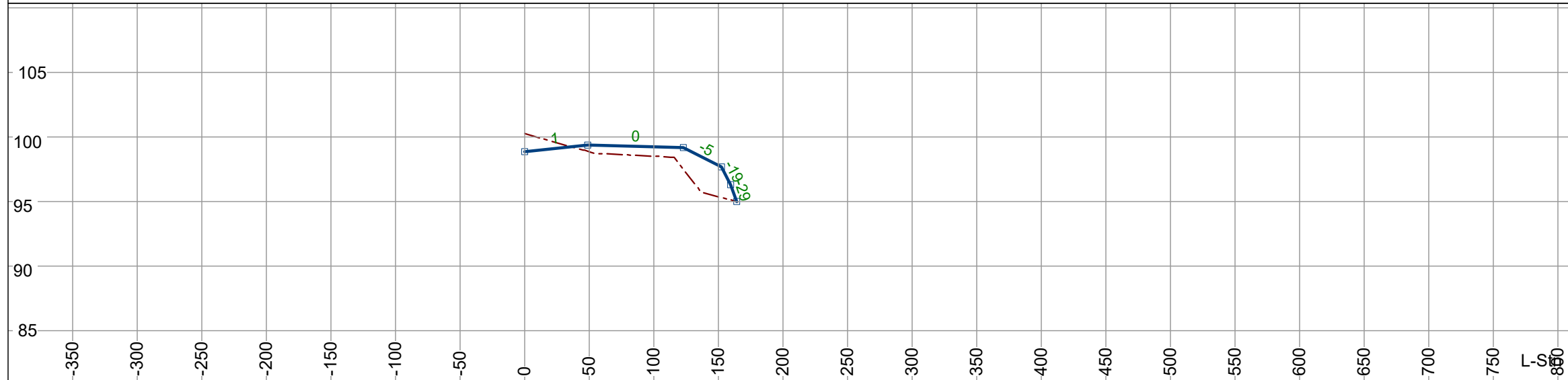

**Profile View**

Template Assignments			
ID	L-Stn From	L-Stn To	Description
DF	..	35.0	DEFAULT TEMP
TP	35.0	60.0	Taper Template
LNDG	60.0	..	Landing

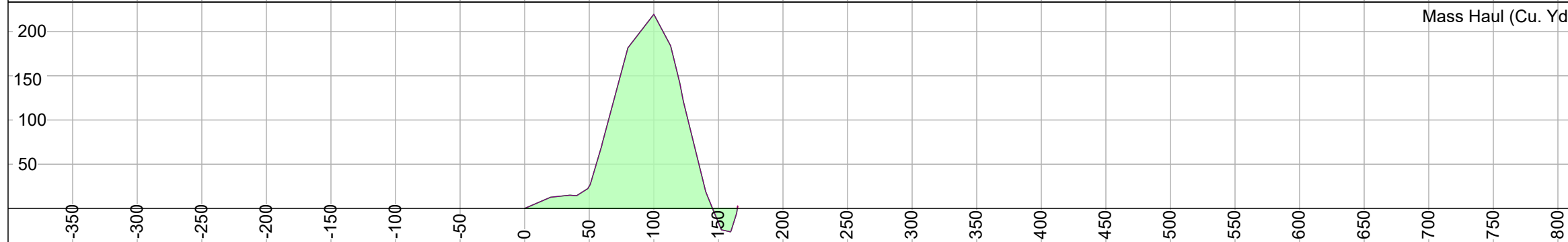

**Mass Haul**



United States  
Department of the Interior  
Bureau of Land Management  
Northwest Oregon District

Timber Sale Contract  
Purchaser Road Maintenance Specifications

SECTION	SHEET	DESCRIPTION
	1	Table of Contents
3000	2	General
3100	2-4	Operational Maintenance
3200	4-5	Seasonal Maintenance
3300	5	Final Maintenance
3400	6	Other Maintenance
3500	6-7	Decommissioning

## ROAD MAINTENANCE SPECIFICATIONS

### GENERAL - 3000

- 3001 The Purchaser shall be required to maintain all roads listed and/or referenced in Section 44, Special Provisions, and as shown on the Exhibit E map of this contract in accordance with Sections 3000, 3100, 3200, 3300 and 3400 of this Exhibit.
- 3002 The Purchaser shall maintain the cross section of existing dirt or graveled roads to the existing geometric standards. Any roads required to be constructed, improved, or renovated under the terms of this contract shall be maintained to the geometric standards required in Exhibit C of this contract.
- 3003 The minimum required maintenance on any roads shall include the provisions specified in Subsections 3101, 3104, and 3105.
- 3004 The Purchaser shall be responsible for providing timely maintenance and cleanup on any roads with logging units substantially completed, prior to moving operations to other roads, unless otherwise permitted by the Authorized Officer. The maximum length of non-maintained or non-cleanup of the road prism shall not exceed the sum of one (1) mile at any time. Release of maintenance requirements may be granted, upon written request, when the conditions specified in Sections 3300 and 3400 are met satisfactorily.

### OPERATIONAL MAINTENANCE - 3100

- 3101 The Purchaser shall blade and shape the road surface and shoulders with a motor grader. Banks shall not be undercut. Back blading with tractors or similar equipment will be allowed only around landings and other areas when approved by the Authorized Officer.
- 3102 The Purchaser shall furnish and place a minimum of 600 cubic yards of 1 ½" aggregate conforming to the requirements in Section 1000 of Exhibit C of this contract on the roadway and landings at locations and in the amounts designated by the Authorized Officer. The aggregate gradation and compacted depth will also be designated by the Authorized Officer. This aggregate shall be used to repair surface failures, landings and areas of depleted surface depth excluding damages covered by Section 12 of this contract. The aggregate shall be furnished, hauled, placed, spread, and compacted by use of dump trucks, water trucks, and motor grader or similar equipment.

OPERATIONAL MAINTENANCE - 3100

- 3103 The purchaser shall maintain established berms and place additional berms using adjacent material where needed to protect fills as directed by the Authorized Officer.
- 3104 The purchaser shall perform other road cleanup including removal of debris, fallen timber, bank slough, and slides which can practicably be accomplished by a motor grader, rubber tired front end bucket loader, rubber tired backhoe or comparable equipment, and by the use of hand tools.
- 3104a Removal of bank slough and slide material includes placement of material at the nearest designated, suitable disposal site where material cannot erode into streams, lakes, or reservoirs or cause undue damage to road fill slopes which have been planted or mulched to control soil erosion as directed by the Authorized Officer.
- 3104b The Purchaser shall be responsible for removal of all slides or slough, up to fifteen station yards in quantity, at any one site. This work includes unlimited multiple sites on all roads required to be maintained by the Purchaser.
- Prior to removal of any slough or slide material exceeding fifteen station yards at any one site, the Purchaser and the Authorized Officer or their Authorized Representatives shall agree in writing, in the field, to the quantity of material, method of disposal, and the disposal site. Work may commence immediately after agreement.
- Upon completion of agreed upon work, a reduction in timber sale purchase price will be made to offset the cost of the work, based on current BLM Road Cost Guide. Adjustments in purchase price for completed work shall be made as necessary and no less than one per year when actual work is ongoing.
- 3105 The Purchaser shall be responsible for maintaining normal flow in drainage structures. This includes cleaning out drainage ditches, catch basins, clearing pipe inverts of sediment and other debris lodged in the barrel of the pipe, and maintaining water dips and water bars using equipment specified in Subsection 3104 and other culvert cleaning and flushing equipment.

OPERATIONAL MAINTENANCE - 3100

3106 The Purchaser shall be responsible for repair and replacement of all materials eroded from road shoulders and fill slopes, up to fifteen station yards in quantity, at any one site. This work includes unlimited multiple sites on all roads required to be maintained by the Purchaser. Prior to repair and replacement of eroded material exceeding fifteen station yards at any one site, the Purchaser and the Authorized Officer or their Authorized Representatives shall agree in writing, in the field, to the quantity of material, borrow source and method of repair. Work may commence immediately after agreement.

Upon completion of agreed upon work, a reduction in timber sale purchase price will be made to offset the cost of the work based upon current BLM Road Cost Guide. Adjustments in purchase price for completed work shall be made as necessary, and no less than once per year when actual work is ongoing.

3107 The Purchaser shall cut or trim trees and brush which obstructs vision or prevents the safe passage of traffic along the traveled way when directed by the Authorized Officer.

The Purchaser shall also cut trees or brush encroaching on the road prism that are a result of his activities or winter damage during the contract period. Disposal of such vegetative material shall be by scattering below the road.

3108 The Purchaser shall avoid fouling gravel or bituminous surfaces through covering with earth and debris from side ditches, slides or other sources. The Purchaser shall also avoid blading surfacing material off the running surface of the roadway. Skidding of logs on the roadway in or outside designated logging units is not authorized without prior written approval by the Authorized Officer. Repair required caused by such skidding activity is not considered maintenance and shall be repaired at the Purchaser's expense.

SEASONAL MAINTENANCE - 3200

3201 The Purchaser shall perform preventative maintenance at the end of Purchaser's hauling each season and during non-hauling periods which occur between other operations on the contract area. This includes requirements specified in Section 3100.

3202 The purchaser shall perform and complete maintenance specified in Sections 3000, 3100, and 3200 on all roads maintained by him, prior to October 31 each year, except as specified in Subsection 3203, after initial commencement of construction or logging operations. Thereafter, all roads shall have continuous preventive maintenance and road cleanup until suspension of seasonal operations. This includes all roads used and not used during the proceeding operating seasons.

SEASONAL MAINTENANCE - 3200

- 3203 The Purchaser shall complete road cleanup and maintenance, as specified in Section 3100, at the completion of logging operations on any roads located in an area separate from the area where logging activities will resume.
- 3204 The Purchaser shall be responsible for performing post storm inspections and maintenance during the winter season to minimize erosion and potential road or watershed damage.

FINAL MAINTENANCE - 3300

- 3301 The Purchaser shall complete final maintenance and/or damage repairs on all roads used under the terms of their contract within thirty (30) calendar days following the completion of hauling and in accordance with Sec. 16 (b) of this contract. This work shall include any maintenance and/or damage repairs specified in Sections 3000, 3100, and 3200 necessary to meet the conditions specified in Subsection 3002 and shall be executed in accordance with Subsection 3302 of this section.

The Authorized Officer may grant acceptance of Purchaser's maintenance responsibility in part where certain individual roads or road segments are no longer of any use to the Purchaser's remaining removal operations, providing that all contract requirements as specified under Sec. 16(b), Special Provisions, Sections 3000, 3100, 3200 and 3300 of the maintenance specifications have been completed and a relinquishment of cutting and removal rights on cutting units tributary to these roads is signed by the Purchaser. Request for partial acceptance must be submitted in writing by the Purchaser.

- 3302 The Purchaser shall perform final road maintenance only when weather or soil moisture conditions are suitable for normal maintenance equipment operations as determined by the Authorized Officer.

If final maintenance is delayed after the date required in Subsection 3301 of this contract by adverse soil moisture or unsuitable equipment operating conditions, the Purchaser will be notified by the Authorized Officer when soil moisture and equipment operating conditions are suitable. The Purchaser shall then be required to complete final maintenance within 30 days.

OTHER MAINTENANCE - 3400

3401 The Purchaser shall repair any damage to road surfaces that was specified under Subsection 3108. This repair includes restoring the roadway to the designed standard and replacement of surfacing with approved surface material. This repair is not limited to use of equipment specified in Subsection 3104.

3402 The Purchaser shall be permitted to remove ice and snow from roads authorized for use under this contract only when prior written approval has been secured from the Authorized Officer. The Purchaser shall submit a written request for permission to remove ice and snow in advance of the date operations are to begin.

Upon receiving written authorization for ice or snow removal, the Purchaser will perform the work according to the conditions and equipment requirements set forth in the authorization.

DECOMMISSIONING – 3500

3501 Decommissioning shall consist of installing water bars, seeding and mulching of exposed soils, and blocking road entrances, as directed by the Authorized Officer and in accordance with Section 2700 of Exhibit C of this contract. Seeding and mulching of exposed soils will be required and must be in accordance with Section 1800 of Exhibit C of this contract.

3503 Decommissioning shall be performed on existing roads in accordance with these specifications, and as shown on the plans at the following locations:

ROAD NO OR SITE	FROM MP/STA.	TO MP/STA.	DECOMMISSION
8-8-11.8	0.16	--	Remove and dispose of 50'x50' corrugated metal pipe. Pull back slopes of pipe trench in order to form blocking berm to limit vehicle traffic.
P5	0.00	0.07	Install 2 water bars/ construct earthen barrier to block road entrance.
P6	0.00	0.10	Install 3 water bars/ construct earthen barrier to block road entrance.



UNITED STATES DEPARTMENT OF THE INTERIOR  
 Bureau of Land Management  
**Road Use and Maintenance Map**  
 T. 8 S. - R. 8 W., Section 11 W.M.

Humbard's  
 ORN02-TS-2024.0203  
**EXHIBIT E**

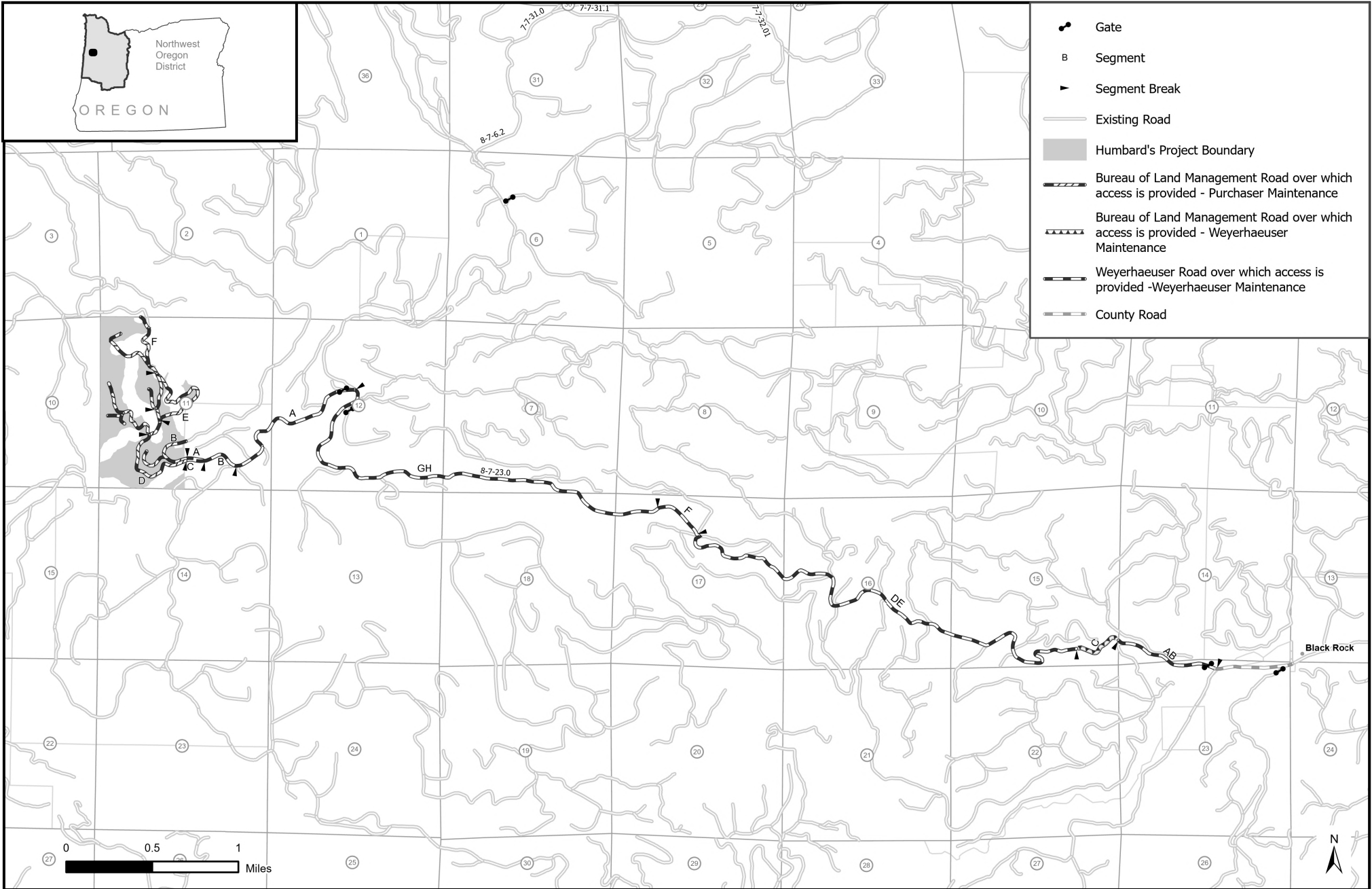

- Gate
- Segment
- Segment Break
- Existing Road
- Humbard's Project Boundary
- Bureau of Land Management Road over which access is provided - Purchaser Maintenance
- Bureau of Land Management Road over which access is provided - Weyerhaeuser Maintenance
- Weyerhaeuser Road over which access is provided -Weyerhaeuser Maintenance
- County Road

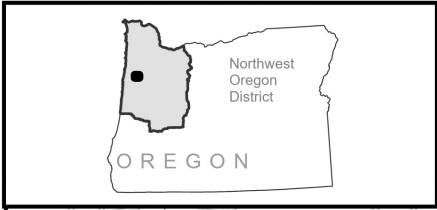



**TIMBER SALE CONTRACT MAP - ORN02-TS-2024.0203**  
 T. 8 S., R. 8 W., Section 11 W.M.

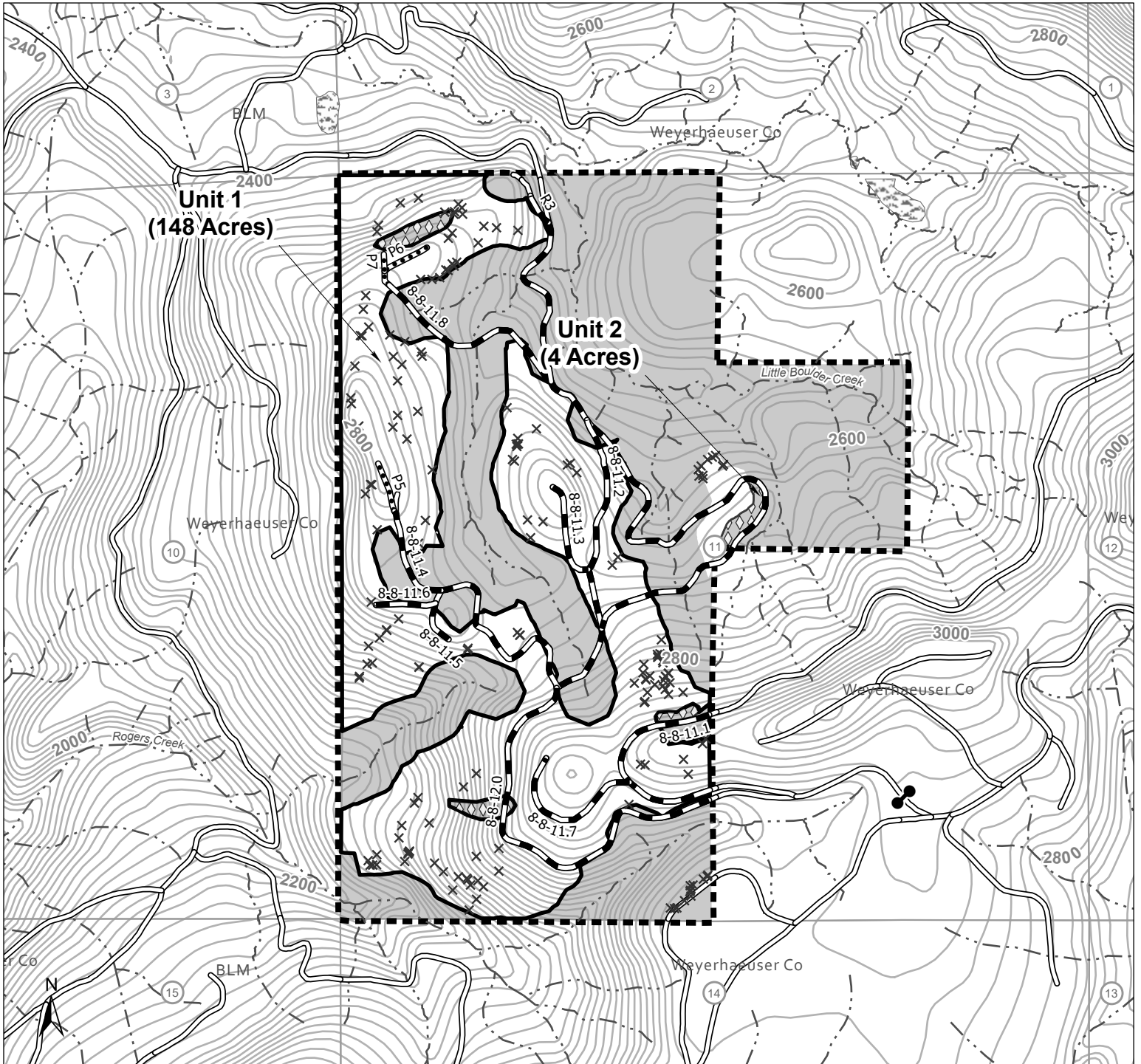

Contour Interval: 40 ft (LiDAR)

- |                              |                        |                          |
|------------------------------|------------------------|--------------------------|
| Boundary Contract Area       | Existing Gate          | Road to be Renovated     |
| Boundary Cutting Area        | Streams                | Existing Road            |
| Yarding allowed Reserve Area | WaterBody              | Snag to be Created (175) |
| Reserve Area                 | Road to be Constructed | Feet<br>0 1,000          |

NOTES: Boundary of Harvest areas are painted yellow and posted. Unit acres do not include existing roads or Rights-of-Way.





**United States  
Department of the Interior  
Bureau of Land Management**

**Timber Appraisal**

---

<b>Sale Name:</b> Humbards TS	<b>Sale Date:</b> Wednesday, August 28, 2024
<b>BLM District:</b> NW Oregon DO	<b>Unit of Measure:</b> 16' MBF
<b>Contract #:</b> ORN02-TS-2024.0203	<b>Contract Term:</b> 36 months
<b>Sale Type:</b> Advertised	<b>Contract Mechanism:</b> 5450-003 Lump Sum Sale of Timber and other Wood Products

---

**Content**

**Timber Appraisal Summary**  
**Stumpage Summary**  
**Unit Summary**  
**Stump to Truck**  
**Transportation**  
**Engineering Allowances**  
**Other Allowances**

Legal Description of Contract Area

Land Status	County	Township	Range	Section	Subdivision	Meridian
O&C	Polk	8S	8W	11	SW1/4 NE1/4, W1/2	Willamette

Species Totals

Species	Net	Gross Merch	Gross	# of Merch Logs	# of Cull Logs	# of Trees
Douglas Fir	4,543.0	4,833.0	4,844.0	33,938	393	5,913
Noble Fir	1,666.0	1,912.0	1,924.0	10,081	265	1,780
Western Hemlock	1,206.0	1,336.0	1,338.0	14,805	52	3,836
<b>Totals</b>	<b>7,415.0</b>	<b>8,081.0</b>	<b>8,106.0</b>	<b>58,824</b>	<b>710</b>	<b>11,529</b>

Cutting Area Acres

Regeneration Harvest Acres	Partial Cut Acres	Right of Way Acres	Total Acres	Net Volume per Acre
152.0	0.0	0.0	152.0	48.8

**Logging Costs**

Stump to Truck	\$1,402,375.13
Transportation	\$834,708.00
Road Construction	\$369,003.24
Maintenance/Rockwear	\$114,004.11
Road Use	\$22,245.00
Other Allowances	\$91,367.23
<b>Total:</b>	<b>\$2,833,702.71</b>
<b>Total Logging Cost per MBF:</b>	<b>\$382.16</b>

**Utilization Centers**

<u>Location</u>	<u>Distance</u>	<u>% of Net Volume</u>
Hampton	86.0 miles	40%
Hampton	40.0 miles	60%

**Profit & Risk**

Profit	11%
Risk	1%
<b>Total Profit &amp; Risk</b>	<b>12%</b>

**Tract Features**

<b>Quadratic Mean DBH</b>	23.7 in
<b>Average GM Log</b>	137 bf
<b>Average Volume per Acre</b>	48.8 mbf
<b>Recovery</b>	91%
<b><u>Net MBF volume:</u></b>	
<b>Green</b>	7,415.0 mbf
<b>Salvage</b>	0 mbf
<b>Export</b>	0 mbf
<b><u>Ground Base Logging:</u></b>	
<b>Percent of Sale Volume</b>	56%
<b>Average Yarding Slope</b>	0%
<b>Average Yarding Distance</b>	0 ft
<b><u>Cable Logging:</u></b>	
<b>Percent of Sale Volume</b>	44%
<b>Average Yarding Slope</b>	0%
<b>Average Yarding Distance</b>	0 ft
<b><u>Aerial Logging:</u></b>	
<b>Percent of Sale Volume</b>	0%
<b>Average Yarding Slope</b>	0%
<b>Average Yarding Distance</b>	0 ft

**Cruise**

<b>Cruise Completed</b>	March 2023
<b>Cruised By</b>	Brian Barclay
<b>Cruise Method</b>	Variable plot cruise, using a 30 BAF for unit 1 and a 40 BAF for unit 2.

**Stumpage Computation**

Species	# of Trees	Net Volume	Pond Value	(-) Profit & Risk	(-) Logging Costs	(+) Marginal Log Value	Appraised Price/MBF	Appraised Value (\$)
Douglas Fir	5,913	4,543.0	\$587.78	\$70.53	\$382.16	\$0.00	\$135.10	\$613,759.30
Noble Fir	1,780	1,666.0	\$463.18	\$55.58	\$382.16	\$0.00	\$46.40 *	\$77,302.40
Western Hemlock	3,836	1,206.0	\$436.27	\$52.35	\$382.16	\$0.00	\$43.70 *	\$52,702.20
<b>Totals</b>	<b>11,529</b>	<b>7,415.0</b>						<b>\$743,763.90</b>

\* Minimum Stumpage values were used to compute the Appraised Price/MBF (10.00% of Pond Value)

**Percent of Volume By Log Grade**

Species	No. 1 & 2 Peeler	No. 3 Peeler	Special Mill	No. 2 Sawmill	No. 3 Sawmill	No. 4 Sawmill	Camp Run
Douglas Fir				91.0%	8.0%	1.0%	

Species	Peeler	No. 1 Sawmill	Special Mill	No. 2 Sawmill	No. 3 Sawmill	No. 4 Sawmill	Camp Run
Noble Fir				93.0%	6.0%	1.0%	

Species	Peeler	No. 1 Sawmill	Special Mill	No. 2 Sawmill	No. 3 Sawmill	No. 4 Sawmill	Camp Run
Western Hemlock				81.0%	15.0%	4.0%	

**Unit: 1**

Species	Net	Gross Merch	Gross	# of Trees
Douglas Fir	4,420.0	4,702.0	4,712.0	5,778
Noble Fir	1,626.0	1,866.0	1,878.0	1,740
Western Hemlock	1,179.0	1,306.0	1,308.0	3,750
<b>Totals:</b>	<b>7,225.0</b>	<b>7,874.0</b>	<b>7,898.0</b>	<b>11,268</b>

**Net Volume/Acre: 48.8 MBF**

Regeneration Harvest	148.0
Partial Cut	0.0
Right of Way	0.0
<b>Total Acres:</b>	<b>148.0</b>

**Unit: 2**

Species	Net	Gross Merch	Gross	# of Trees
Douglas Fir	123.0	131.0	132.0	135
Noble Fir	40.0	46.0	46.0	40
Western Hemlock	27.0	30.0	30.0	86
<b>Totals:</b>	<b>190.0</b>	<b>207.0</b>	<b>208.0</b>	<b>261</b>

**Net Volume/Acre: 47.5 MBF**

Regeneration Harvest	4.0
Partial Cut	0.0
Right of Way	0.0
<b>Total Acres:</b>	<b>4.0</b>

<b>Total Stump To Truck</b>	<b>Net Volume</b>	<b>\$/MBF</b>
\$1,402,375.13	7,415.0	\$189.13

**Stump to Truck: Falling, Bucking, Yarding, & Loading**

Yarding System	Unit of Measure	# of Units of Measure	\$/Unit of Measure	Total Cost	Remarks
Cable: Large Yarder	GM MBF	4,525.0	\$183.41	\$829,930.25	Total includes the cost of yarded, processor, loader and 2 manual fellers
Track Skidder	GM MBF	3,556.0	\$160.98	\$572,444.88	Total includes the cost of track skidder, feller buncher, processor and loader
<b>Subtotal</b>				<b>\$1,402,375.13</b>	

**Additional Costs**

Item	Unit of Measure	# of Units of Measure	\$/Unit of Measure	Total Cost	Remarks
<b>Subtotal</b>				<b>\$0.00</b>	

**Additional Moves**

Equipment	Unit of Measure	# of Units of Measure	\$/Unit of Measure	Total Cost	Remarks
<b>Subtotal</b>				<b>\$0.00</b>	

Total	Net Volume	\$/MBF
\$834,708.00	7,415.0	\$112.57

Utilization Center	One Way Mileage	Description	Unit of Measure	# of Units	\$/Unit of Measure	Total Cost	% of Sale Volume
Hampton	86.0	Hampton mill Tillamook whitewoods	GM MBF	3,248.0	\$132.00	\$428,736.00	40%
Hampton	40.0	Hampton Mill Willamina Douglas fir	GM MBF	4,833.0	\$84.00	\$405,972.00	60%

**Comments:**

-5.5 hours round trip to Tillamook with 5 mbf/load @\$120/hr = \$132/mbf

-3.5 hours round trip to Willamina with 5mbf/load @\$120/hr = \$84/mbf

**Engineering Allowances**

Total	Net Volume	\$/MBF
\$505,252.35	7,415.0	\$68.14

Cost Item	Total Cost
Road Construction:	\$369,003.24
Road Maintenance/Rockwear:	\$114,004.11
Road Use Fees:	\$22,245.00

<b>Total</b>	<b>Net Volume</b>	<b>\$/MBF</b>
\$91,367.23	7,415.0	\$12.32

---



### Environmental Protection

Cost item	Total Cost
Grass seeding	\$280.00
Grass seed 40# Bag	\$640.00
Machine Washing	\$400.00
<b>Subtotal</b>	<b>\$1,320.00</b>

### Miscellaneous

Cost item	Total Cost
Base Girdling	\$1,770.00
High Girdling	\$5,700.00
Tree Topping	\$9,975.00
Machine Washing	\$400.00
10% Admin Fee	\$1,622.50
<b>Subtotal</b>	<b>\$19,467.50</b>

### Road Construction, Maintenance, Use, & Decommissioning

Cost item	Total Cost
Decommissioning	\$2,420.91
Purchaser Maintenance	\$46,608.82
<b>Subtotal</b>	<b>\$49,029.73</b>

### Slash Disposal & Site Prep

Cost item	Total Cost
Landing Pile Burn	\$200.00
Machine Pile Burn	\$5,000.00
Landing Pile Cover	\$350.00
Machine pile construction & Cover	\$16,000.00
<b>Subtotal</b>	<b>\$21,550.00</b>

---