

U.S. Department of the Interior
Bureau of Land Management

BLM Regulation: Produced Water

OFWMS March 2024





Learning objectives

- Bureau of Land Management (BLM) Mission
- BLM Oil & Gas Management Program Overview
- BLM Water Regulation in the Oil & Gas Program
 - 43 CFR 3160s
- June 16, 2023: Final codification of Onshore Orders
 - 43 CFR 3171 (Onshore Oil and Gas Order No. 1)
 - 43 CFR 3177 (Onshore Oil and Gas Order No. 7)



Bureau of Land Management

Mission:

The Bureau of Land Management's mission is to sustain the health, diversity, and productivity of public lands for the use and enjoyment of present and future generations.



What is Department of Interior's role?

Ensure the American public, Indian tribes, and Indian allottees receive a fair royalty in exchange for the production of our/their oil and gas

What is the BLM's role?

Ensure the quantity and quality of oil and gas removed or sold from Federal and Indian leases is accurately measured and properly reported.



What is the Office of Natural Resources Revenue's (ONRR) role?

Ensure the value of oil and gas removed or sold from Federal and Indian leases used for royalty determination represents a fair market value.

Collect and distribute royalty.



BLM Jurisdiction and Responsibility

- 258 million acres of public land (BLM)
- 325 million acres of other federal land
- 60 million acres of Indian trust land
- 57 million acres of split estate

700 million acres

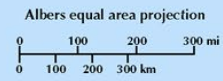



Bureau of Land Management

Oil and Gas from Federal Land:

- 23,500 producible oil and gas leases
- 12.4 million acres of producible oil and gas leases
- 89,000 producing wells
- Oil and gas royalty Dec 2021 to Nov 2022: \approx \$ 9.3 Billion



Government Accountability Office (GAO)



U.S. Department of the Interior Oil and Gas Accountability



Office of Inspector
General (OIG)

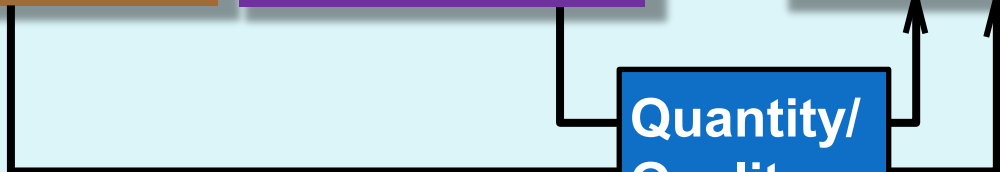



BLM & Water Regulation

§ 3160.0-5 Definitions

Fresh water means water containing not more than 1,000 ppm of total dissolved solids, provided that such water does not contain objectionable levels of any constituent that is toxic to animal, plant or aquatic life, unless otherwise specified in applicable notices or orders.



BLM & Water Regulation

§ 3162.3-4 Well abandonment

(a) The **operator** shall promptly plug and abandon, in accordance with a plan first approved in **writing** or prescribed by the authorized officer, each newly completed or recompleted well in which oil or gas is not encountered in paying quantities or which, after being completed as a producing well, is demonstrated to the satisfaction of the authorized officer to be no longer capable of producing oil or gas in paying quantities, unless the authorized officer shall approve the use of the well as a service well for injection to recover additional oil or gas or for subsurface disposal of produced water. In the case of a newly drilled or recompleted well, the approval to abandon may be written or oral with written confirmation.



BLM & Water Regulation

§ 3162.3-4 Well abandonment

(b) Completion of a well as plugged and abandoned may also include conditioning the well as water supply source for **lease** operations or for use by the surface owner or appropriate Government Agency, when authorized by the authorized officer. All costs over and above the normal plugging and abandonment expense will be paid by the party accepting the water well.



BLM & Water Regulation

§ 3162.4-2 Samples, tests, and surveys.

- (a) During the drilling and completion of a well, the operator shall, when required by the authorized officer, conduct tests, run logs, and make other surveys reasonably necessary to determine the presence, quantity, and quality of oil, gas, other minerals, or the presence or quality of water; to determine the amount and/or direction of deviation of any well from the vertical; and to determine the relevant characteristics of the oil and gas reservoirs penetrated.
- (b) After the well has been completed, the operator shall conduct periodic well tests which will demonstrate the quantity and quality of oil and gas and water. The method and frequency of such well tests will be specified in appropriate notices and orders. When needed, the operator shall conduct reasonable tests which will demonstrate the mechanical integrity of the downhole equipment.



BLM & Water Regulation

§ 3162.5-1 Environmental obligations.

(b) The operator shall exercise due care and diligence to assure that leasehold operations do not result in undue damage to surface or subsurface resources or surface improvements. All produced water must be disposed of by injection into the subsurface, by approved pits, or by other methods which have been approved by the authorized officer. Upon the conclusion of operations, the operator shall reclaim the disturbed surface in a manner approved or reasonably prescribed by the authorized officer.

(c) All spills or leakages of oil, gas, produced water, toxic liquids, or waste materials, blowouts, fires, personal injuries, and fatalities shall be reported by the operator in accordance with these regulations and as prescribed in applicable order or notices. The operator shall exercise due diligence in taking necessary measures, subject to approval by the authorized officer, to control and remove pollutants and to extinguish fires. An operator's compliance with the requirements of the regulations in this part shall not relieve the operator of the obligation to comply with other applicable laws and regulations.



BLM & Water Regulation

§ 3162.5-2 Control of wells.

(d) ***Protection of fresh water and other minerals.*** The operator shall isolate freshwater-bearing and other usable water containing 5,000 ppm or less of dissolved solids and other mineral-bearing formations and protect them from contamination. Tests and surveys of the effectiveness of such measures shall be conducted by the operator using procedures and practices approved or prescribed by the authorized officer.



BLM & Water Regulation

§ 3164.3 Surface rights.

(b) Except for the National Forest System lands, the authorized officer is responsible for approving and supervising the surface use of all drilling, development, and production activities on the leasehold. This includes storage tanks and processing facilities, sales facilities, all pipelines upstream from such facilities, and other facilities to aid production such as water disposal pits and lines, and gas or water injection lines.



BLM & Water Regulation

43 CFR Subpart 3171: Approval of Operations (88 FR 39516)

§ 3171.7 Drilling Plan.

(b) Estimated depth and thickness of formations, members, or zones potentially containing usable water, oil, gas, or prospectively valuable deposits of other minerals that the operator expects to encounter, and the operator's plans for protecting such resources.



BLM & Water Regulation

43 CFR 3171: Approval of Operations (88 FR 39516)

§ 3171.8(a)(2) The Surface Use Plan of Operations must: Provide for safe operations, adequate protection of surface resources, groundwater, and other environmental components;

§ 3171.8(e)(5) Location and Types of Water Supply: Information concerning water supply, such as rivers, creeks, springs, lakes, ponds, and wells, may be shown by quarter-quarter section on a map or plat, or may be described in writing. The operator must identify the source, access route, and transportation method for all water anticipated for use in drilling the proposed well. The operator must describe any newly constructed or reconstructed access roads crossing Federal or Indian lands that are needed to haul the water as provided in paragraph (e)(2) of this section. The operator must indicate if it plans to drill a water supply well on the lease and, if so, the operator must describe the location, construction details, and expected production requirements, including a description of how water will be transported and procedures for well abandonment.



BLM & Water Regulation

43 CFR Subpart 3171: Approval of Operations (88 FR 39516)

§ 3171.8(e)(7) *Methods for Handling Waste*. The Surface Use Plan of Operations must contain a written description of the methods and locations proposed for safe containment and disposal of each type of waste material (e.g., cuttings, garbage, salts, chemicals, sewage, etc.) that results from drilling the proposed well. The narrative must include plans for the eventual disposal of drilling fluids and any produced oil or water recovered during testing operations. The operator must describe plans for the construction and lining, if necessary, of the reserve pit.



BLM & Water Regulation

43 CFR Subpart 3171: Approval of Operations (88 FR 39516)

§ 3171.22(a) *Conversion to an Injection Well*

When subsequent operations will result in a well being converted to a Class II injection well (i.e., for disposal of produced water, oil and gas production enhancement, or underground storage of hydrocarbons), the operator must file with the appropriate BLM office a Sundry Notice, Notice of Intent to Convert to Injection on Form 3160-5.



BLM & Water Regulation

43 CFR Subpart 3171: Approval of Operations (88 FR 39516)

§ 3171.22(b) *Conversion to a Water Supply Well*

In cases where the Surface Managing Agency or private surface owner desires to acquire an oil and gas well and convert it to a water supply well or acquire a water supply well that was drilled by the operator to support lease operations, the Surface Managing Agency or private surface owner must inform the appropriate BLM office of its intent before the approval of the APD in the case of a dry hole and no later than the time a Notice of Intent to Abandon is submitted for a depleted production well. The operator must abandon the well according to BLM instructions, and must complete the surface cleanup and reclamation, in conjunction with the approved APD, Surface Use Plan of Operations, or Notice of Intent to Abandon, if the BLM or the FS require it. The Surface Managing Agency or private surface owner must reach agreement with the operator as to the satisfactory completion of reclamation operations before the BLM will approve any abandonment or reclamation. The BLM approval of the partial abandonment under this section, completion of any required reclamation operations, and the signed release agreement will relieve the operator of further obligation for the well. If the Surface Managing Agency or private surface owner acquires the well for water use purposes, the party acquiring the well assumes liability for the well.



BLM & Water Regulation

43 CFR Subpart 3177 Disposal of Produced Water (88 FR 39540)

§ 3177.5(a) *General Requirements.*

All produced water from Federal/Indian leases must be disposed of by injection into the subsurface, discharging into pits, or other acceptable methods approved by the authorized officer, including surface discharge under NPDES permit. Injection is generally the preferred method of disposal.

§ 3177.5(c)(2) If the approval for a disposal facility, e.g., commercial pit or Class II injection well, is revoked or suspended by the permitting agencies, such as the Environmental Protection Agency or the primacy State, the BLM water disposal approval is immediately terminated and the operator is required to propose an alternative disposal method.



BLM & Water Regulation

43 CFR Subpart 3177 Disposal of Produced Water (88 FR 39540)

§ 3177.6 Applications and approval authority.

(a) On-lease Disposal

(1) Disposal of water in injection wells.

(2) Disposal of water in pits.

(b) Off-lease Disposal

(1) On leased or unleased Federal/Indian lands

The purpose of the off-lease disposal process is to ensure that the removal of the produced water from a Federal or Indian oil and gas lease is proper and that the water is disposed of in an authorized facility.

i. Disposal of water in injection wells.

ii. Disposal of water in pits.

iii. Right-of-way procedure



BLM & Water Regulation

43 CFR Subpart 3177 Disposal of Produced Water (88 FR 39540)

Continued:

- (2) Disposal of water on State- and privately-owned lands
 - i. Disposal of water in injection wells. (copy of UIC permit to BLM)
 - ii. Disposal of water in pits. (copy of State or other regulatory agency permit to BLM)
 - iii. Right-of-way procedures. If the water produced from wells on lease Federal and/or Indian lands, and to be disposed of at a location on State or privately-owned lands, will be transported over off-lease Federal or Indian lands, the operator of the disposal facility or other responsible party shall have a ROW authorization.



BLM & Water Regulation

43 CFR Subpart 3177 Disposal of Produced Water (88 FR 39540)

§ 3177.7 Informational requirements for injection wells.

The operator shall obtain a UIC permit pursuant to 40 CFR parts 144 and 146 from EPA or State/Tribe where State/Tribe has achieved primacy.



BLM & Water Regulation

43 CFR Subpart 3177 Disposal of Produced Water (88 FR 39540)

§ 3177.8 Informational requirements for pits.

Request approval of disposal into lined or unlined pit via Sundry Notice.

Sources of water identified, contingency plan (if requested), all samples for water analysis taken at the discharge point, reclamation plan for closure of pit submitted prior to pit abandonment.

Contingency plan deals with specific anticipated emergency situations.



BLM & Water Regulation

43 CFR Subpart 3177 Disposal of Produced Water (88 FR 39540)

§ 3177.8(a) Lined pit application must contain the following:

- Map or drawing of site to scale including pit dimensions, cross section, side slopes, lead detection system, relative location to other site facilities
- Daily quantity of water disposed of, water analysis including concentration of chlorides, sulfates, pH, TDS, and toxic constituents reasonably believed to be present
- Criteria used to determine the pit size including a minimum of 2 ft of freeboard
- Average monthly evaporation and precipitation for the area



BLM & Water Regulation

43 CFR Subpart 3177 Disposal of Produced Water (88 FR 39540)

Continued:

- Method and schedule for periodic disposal of precipitated solids
- Type, thickness, and life span of material used for lining the pit and the method of installation. Include manufacturer's specifications if available



BLM & Water Regulation

43 CFR Subpart 3177 Disposal of Produced Water (88 FR 39540)

§ 3177.8(b)(1) Unlined pit application must show the disposal meets one of the following criteria:

- i. Water to be disposed of has an annual average TDS concentration \leq than that of the existing water to be protected, provided that the level of any toxic constituents in the produced water does not exceed established State or Federal standards for protection of surface and/or ground water.
- ii. All, or a substantial part, of the produced water is being used for beneficial purposes and meets the minimum water quality standards for such uses.



BLM & Water Regulation

43 CFR Subpart 3177 Disposal of Produced Water (88 FR 39540)

Continued:

iii. (A) Disposed water will not degrade the quality of surface or subsurface waters in the area.

(B) The surface and subsurface waters contain TDS above 10,000 ppm, toxic constituents in high concentrations; or

(C) Surface and subsurface waters are of such poor quality or small quantity as to eliminate any practical use thereof.

iv. Volume of disposed water per facility does not exceed an average of 5 BPD on a monthly basis



BLM & Water Regulation

43 CFR Subpart 3177 Disposal of Produced Water (88 FR 39540)

(2) Operators applying for disposal into an unlined pit must submit the following:

- Map or drawing of site to scale including pit dimensions, cross section, side slopes, lead detection system, relative location to other site facilities

- Daily quantity of water disposed of, water analysis including concentration of chlorides, sulfates, pH, TDS, and constituents toxic to animal or plant life. Applicant should indicate any effector interaction of produced water with any water resources present at or near the surface & other known mineral deposits



BLM & Water Regulation

43 CFR Subpart 3177 Disposal of Produced Water (88 FR 39540)

Continued:

- Average monthly evaporation and precipitation for the area
 - Estimate percolation rate based on soil characteristics under and adjacent to the pit. Authorized Officer may require percolation tests
 - Estimated depth and areal extent of the shallowest known aquifer with TDS less than 10,000 ppm, and the depth and extent of any known mineral deposits in the area
- (ii) Where beneficial use is the basis for the application, the justification shall also contain written confirmation from the user(s)



BLM & Water Regulation

43 CFR Subpart 3177 Disposal of Produced Water (88 FR 39540)

Continued:

iii. If applying on the basis that surface and subsurface waters will not be adversely affected by disposal in an unlined pit, the justification must include the following additional information:

- Map of the site showing the location of surface waters, water wells, and existing water disposal facilities within 1 mile of the proposed disposal facility
- Average concentration of TDS of all surface and subsurface waters within the 1-mile radius that might be affected by the proposed disposal
- Copy of any State order or other authorization granted as a result of a public hearing that is pertinent to the AO's decision making



BLM & Water Regulation

43 CFR Subpart 3177 Disposal of Produced Water (88 FR 39540)

(c) *Emergency pits.*

Design for an emergency pit will be established by the AO on a case-by-case basis.

Any emergency use of such pits must be reported in accordance with NTL-3A (Reporting of Undesirable Events)

Pit must be emptied and the liquids disposed of in accordance with applicable State and/or Federal regulations within 48 hours following its use, unless extended by the AO



BLM & Water Regulation

43 CFR Subpart 3177 Disposal of Produced Water (88 FR 39540)

§ 3177.9 *Design requirements for pits.*

(a) Pits must meet the following requirements:

(1) As much as is practical, the pit must be located on level ground and away from established drainage patterns, including intermittent/ephemeral drainage ways, and unstable group or depressions in the area

(2) Pit must have adequate storage capacity for safe containment of all produced water, even when evaporation rates are at a minimum. Design must provide for a minimum of 2 ft of free-board



BLM & Water Regulation

43 CFR Subpart 3177 Disposal of Produced Water (88 FR 39540)

Continued:

(3) The pit must be fenced or enclosed to prevent access by livestock, wildlife, and unauthorized personnel. If necessary, the pit must be equipped to deter entry by birds. Fences must not be constructed on levees. (Figure 1 in Appendix A)



BLM & Water Regulation

43 CFR Subpart 3177 Disposal of Produced Water (88 FR 39540)

Figure 1. Examples for Design and Construction of Fences and Corner Posts

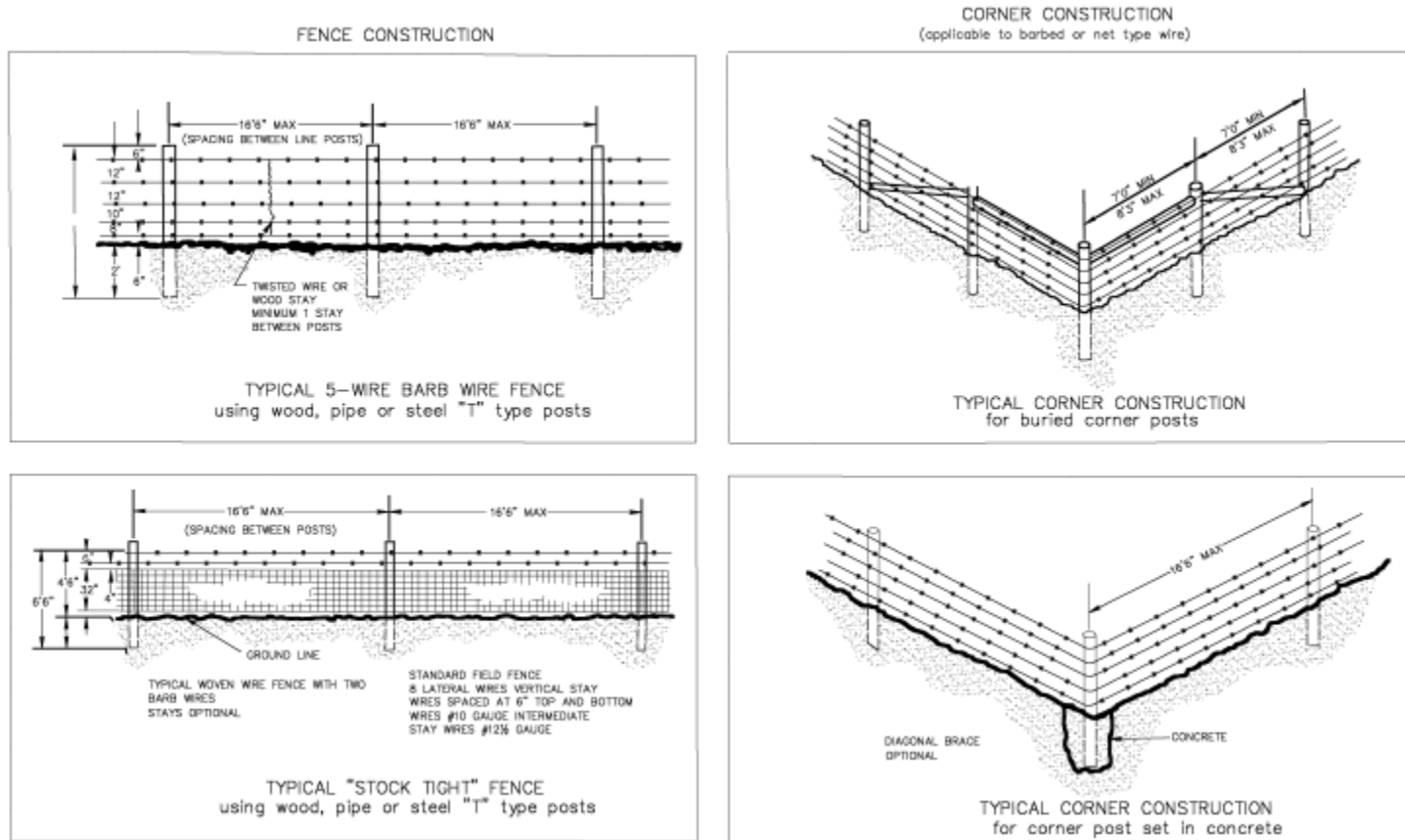



BLM & Water Regulation

43 CFR Subpart 3177 Disposal of Produced Water (88 FR 39540)

Continued:

- (4) The pit levees are to be constructed so that the inside grade of the levee is no steeper than 1 (vertical):2 (horizontal), and the outside grade no steeper than 1:3.
- (5) Top of the levee must be level and at least 18 in wide.
- (6) Pit location must be reclaimed. On split estate (private surface, Federal mineral) a surface owner's release statement or form is acceptable



BLM & Water Regulation

43 CFR Subpart 3177 Disposal of Produced Water (88 FR 39540)

§ 3177.9(b) Lined pits must meet the requirements in paragraph (a) of this section and the following requirements:

(1) Material used to line the pits must be impervious, resistant to weather, sunlight, hydrocarbons, aqueous acids, alkalies, salt, fungi, or other substances likely to be contained in the produced water.

(2) If rigid materials are used, leak-proof expansion joints must be used, or the material must be of sufficient thickness and strength to withstand expansion without cracking, contraction, and settling movements in the underlying earth. Semirigid liners such as compacted bentonite or clay may be used provided that the liner is impervious for the expected period of use (Figure 2 in appendix A).

BLM & Water Regulation

Figure 2. Example of Acceptable Design for Concrete, Asphalt, and Bentonite/Clay Liners

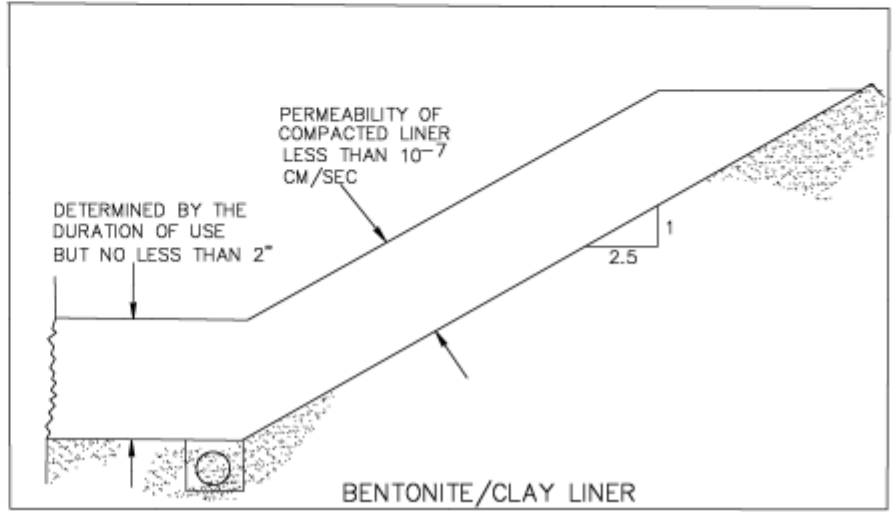
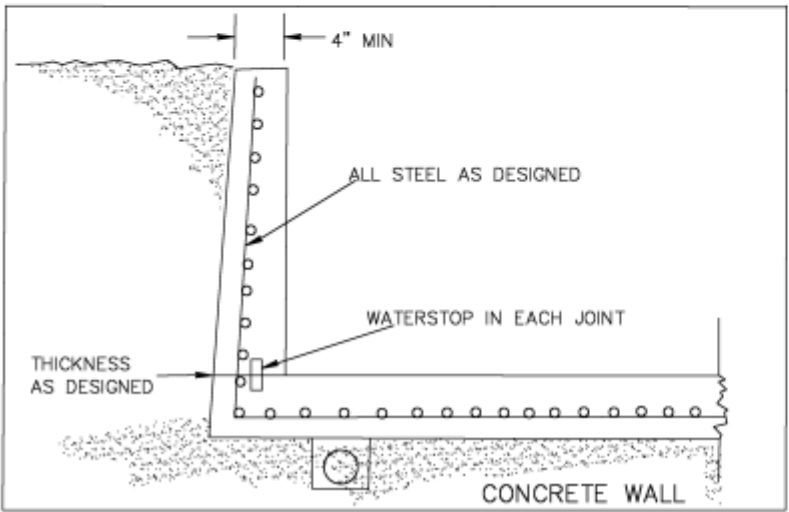
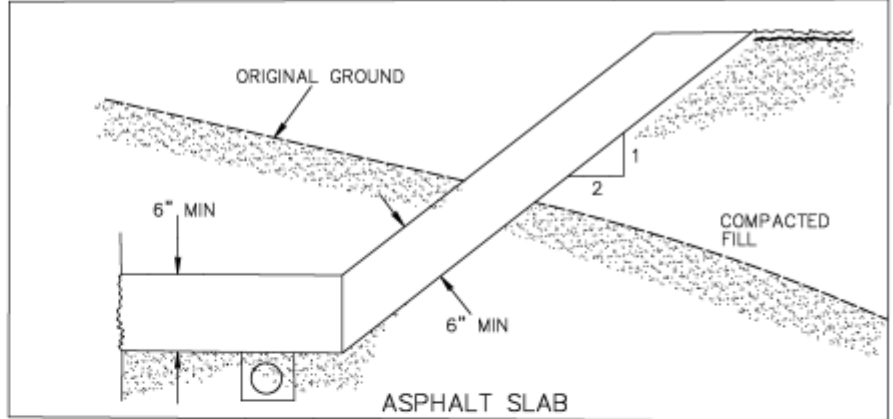
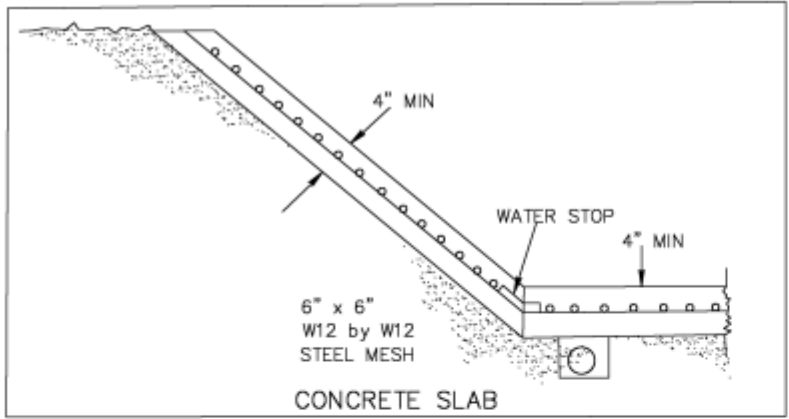



BLM & Water Regulation

43 CFR Subpart 3177 Disposal of Produced Water (88 FR 39540)

Continued:

(3) If flexible membrane materials are used, they must have adequate resistance to tears and punctures (Figure 3 in appendix A).



BLM & Water Regulation

Figure 3. Example of Acceptable Design of a Flexible Liner

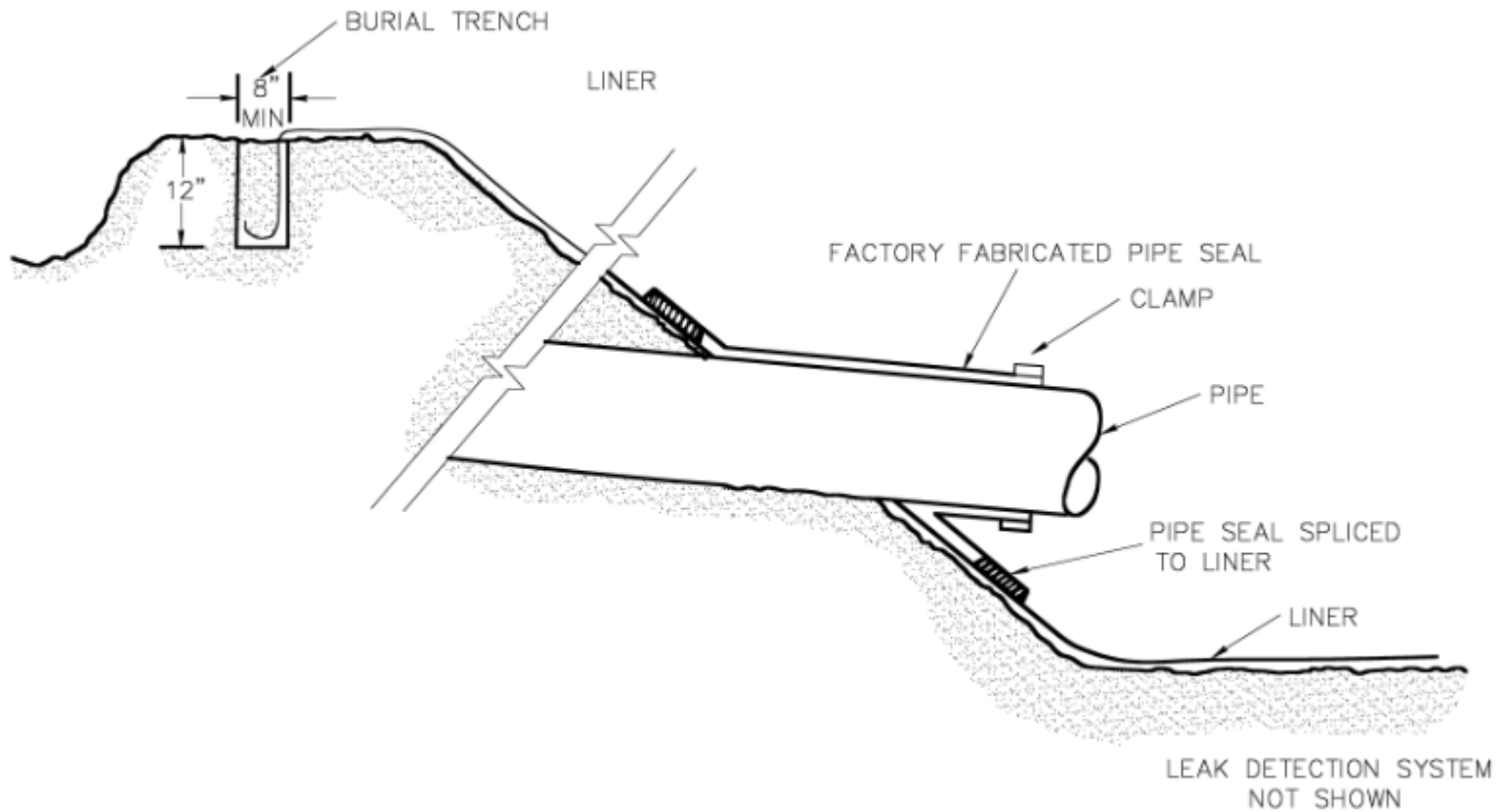



BLM & Water Regulation

43 CFR Subpart 3177 Disposal of Produced Water (88 FR 39540)

Continued:

(4) Lined pits must have an underlying gravel-filled sump and lateral system or other suitable devices for detection of leaks (Figures 4 & 5 of appendix A).

BLM & Water Regulation

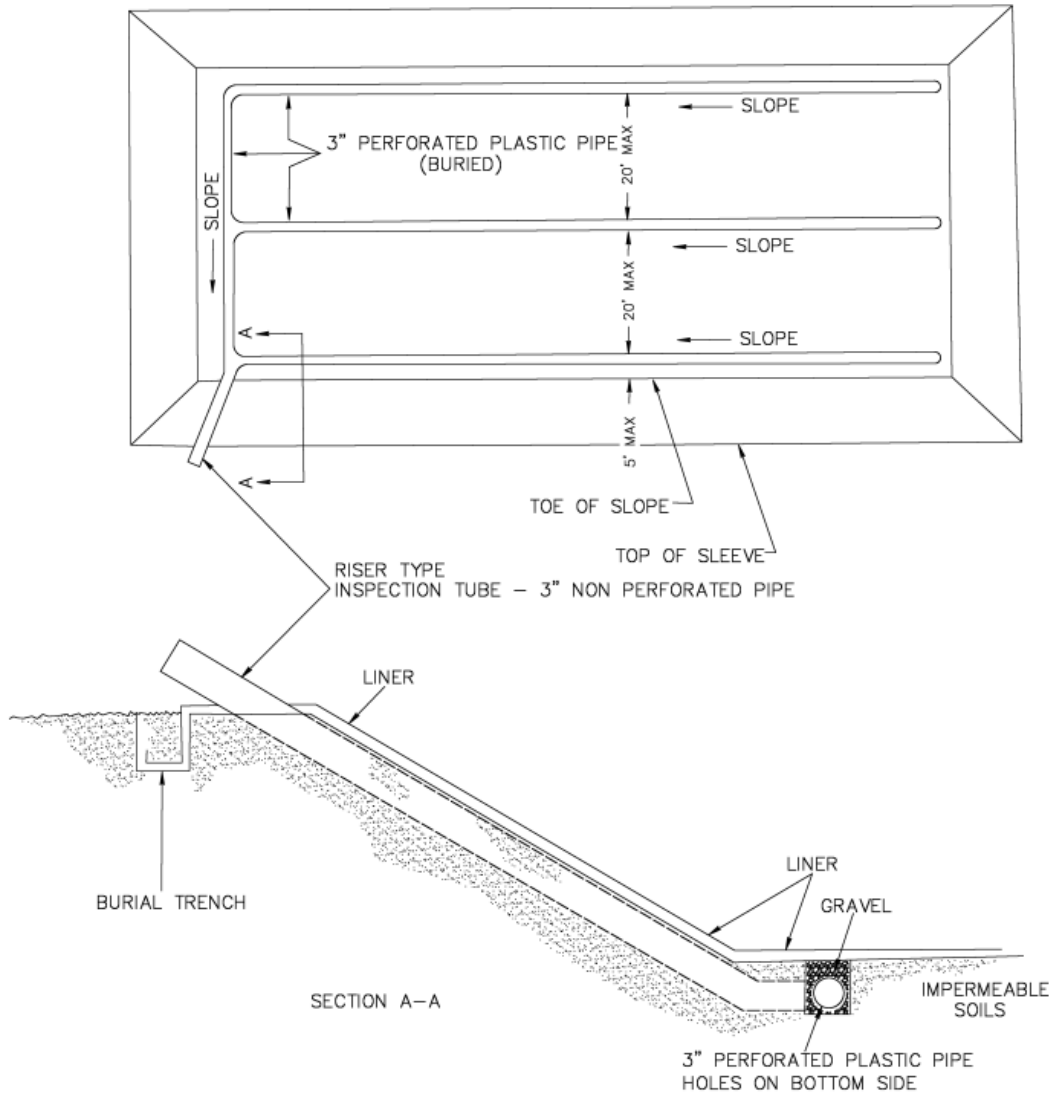

Figure 4. Example of a Leak Detection System for a Lined Pit Constructed in Relatively Impermeable Soils



BLM & Water Regulation

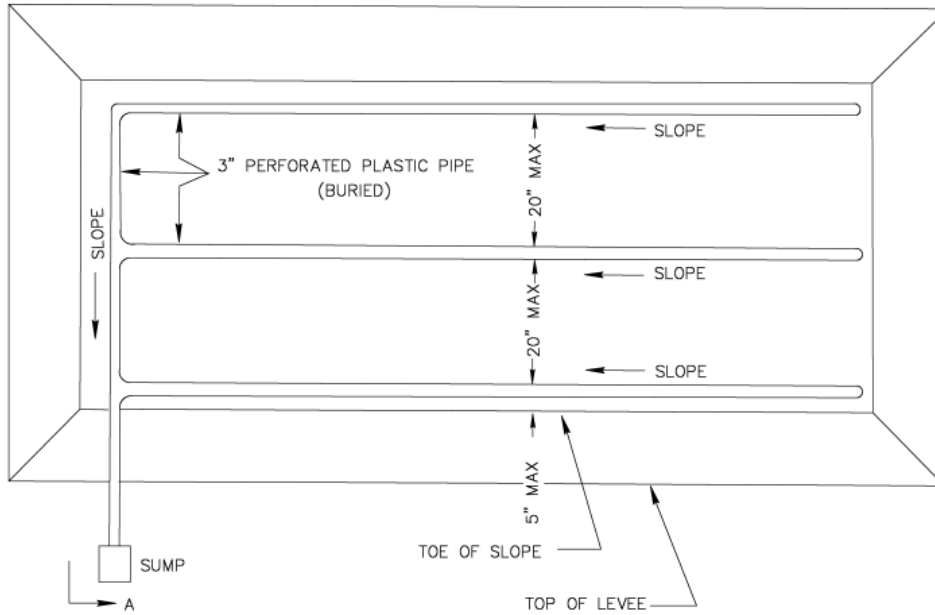
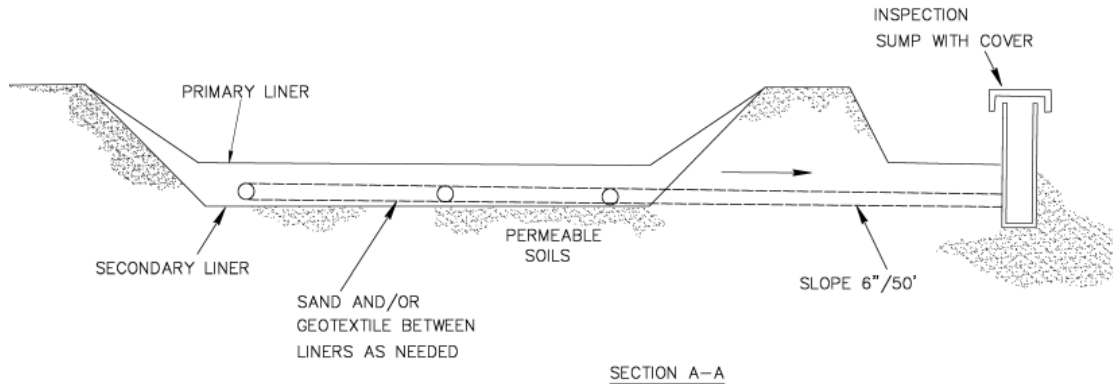

Figure 5. Example of a Leak Detection System for a Lined Pit Constructed in Permeable Soils (58 FR 47369)





BLM & Water Regulation

Questions?